

Appendix F – Design Report prepared by ALUA

Victoria Park-Canning Level Crossing Removal Development Application Design Report - Wharf Street Package

June 2023



We acknowledge and respect the Nyoongar Whadjuk People as the original Custodians of the land and acknowledge their unique ability to care for Country and their deep spiritual connection to it. We honour Elders past, present and emerging whose knowledge and wisdom has, and will, ensure the continuation of cultures and traditional practices.

Cover Illustration Adapted From METRONET Place Plan LXR-MNO-MET-PN-STR-0001

Approval

Author Signature		Checker Signature	
Name	Robina Crook	Name	Hannah Galloway
Title	Planner and Urban design	Title	Landscape Architecture Lead

Approver Signature		SEM Signature	
Name	Ben Hoy	Name	Erica Berrenger
Title	Design Delivery Manager	Title	Design & Stakeholder Director

ASSUMPTIONS and DISCLAIMER

The information contained within this report has been prepared with due care and diligence to ensure correct and accurate information is provided. However, should the assumptions made and information provided in preparing this report prove to be erroneous or misleading in any way, beyond the control of the Project Design Team, ALUA accept no responsibility.



CONTENTS

01

Urban Design Brief

- 1.1 Defining the Project Scope
- 1.2 Place Plan - Queens Park Station
- 1.3 Place Plan - Cannington Station

02

Design Principles

- 2.1 Vision
- 2.2 Landscape and Urban Design Principles

03

Design Narrative

- 3.1 Design Narrative Overview
- 3.2 Collective Energy of Country
- 3.3 Connected Connection to Country
- 3.4 Specific Celebration of Place
- 3.5 Station Narrative
- 3.6 Structure Narrative

04

Design Strategies

- 4.1 Opportunity
- 4.2 Concept
- 4.3 Design Strategies
- 4.4 Urban Design Approach

05

Design Solution

- 5.1 Design Overview
- 5.2 Master Plan & Station Precincts
- 5.3 Queens Park Station
- 5.4 Cannington Station

06

Stations

- 6.1 Station Design Introduction
- 6.2 State Planning Policy 7.0
- 6.3 Noongar Place Names
- 6.4 Color Identity
- 6.5 Brickwork
- 6.6 Platform & Concourse Tiles
- 6.7 Queens Park Station
- 6.8 Cannington Station

07

Activation

- 7.1 Activation
- 7.2 Activation Strategy
- 7.3 Activation Nodes
- 7.4 Play Strategy
- 7.5 Divergent Play Strategy
- 7.6 Railway Dog Park
- 7.7 Youran Play Space
- 7.8 Water HQ
- 7.9 Queens Park Community Hub
- 7.10 Rail Yard Adventure Play Space
- 7.11 Cannington Youth Plaza
- 7.12 Cannington Climbing & Basin

08

Environment

- 8.1 Sustainability Strategy
- 8.2 Green Star
- 8.3 Tree Planting
- 8.4 Existing Trees
- 8.5 Proposed Trees
- 8.6 Tree Planting Offsets
- 8.7 Planting Strategy
- 8.8 Shade Study
- 8.9 Planting Strategy
- 8.10 Planting Palette
- 8.11 Water Sensitive Urban Design

09

Interpretation

- 9.1 Interpretation
- 9.2 Site Curatorial Themes
- 9.3 Key Opportunities
- 9.4 Materials Strategy

10

Movement

- 10.1 Movement Strategy
- 10.2 PSP Crossing Strategy
- 10.3 Specific Access Plans
- 10.4 Security & CPTED Strategy
- 10.5 Lighting Strategy

01 URBAN DESIGN BRIEF

1.1 DEFINING THE PROJECT SCOPE

The Final Place Plans

The design for this project builds upon work undertaken in the preparation of the following documents

- Preliminary Place Plans (PPP)
- Landscape Concept Design (LCD)

These two documents along with the Scope of Works and Technical Criteria (SWTC) have defined the scope for the delivery of this project as illustrated in the adjacent diagram.

The project detailed design expands and develops the research, principles and thinking included within all vision and briefing documentation provided by METRONET.

Final Place Plans have been created for each station precinct to inform an integrated approach to the linear park and station design. They provide an understanding of the urban context and recommendations for development.

The Final Place Plans identify opportunities beyond the current site works guiding the integration of development within and external to the site. They demonstrate how connection, activation and landscape can support the long-term vision for the precincts.

The Final Place Plans ensure that insights uncovered through preparation of the PPP and LCD along with community and stakeholders engagement outcomes are integrated into the final design outcome, responding to the specific needs of a local community.

The Final Place Plans detail the:

- Project background and the importance of METRONET's integrated land use and transport vision
- Alignment with METRONET and PTA objectives
- Importance of the regional, local and site contexts
- Existing engagement outcomes and an ongoing engagement process

- Reflects on the purpose of an enriched, authentic sense of place within its context
- Provides an evolution of the place narrative and establishes a sense of place statement
- The strategic drivers of place including enhanced sustainability, reinforce identify, encourage connections, community, safety, and activation.
- It establishes the good principles of station precinct design, demonstrating alignment with the State Planning Policy 7.0 - Design.
- The local place principles are outlines, with specific ideas for place activation and landscape opportunities.
- The public art strategy is included detailing the need for connection to the established narrative.

Final Place Plans

The following section of this document extracts the specific place principles from the Final Place Plans for each station and outlines how they are addressed by the current Design for the precinct.

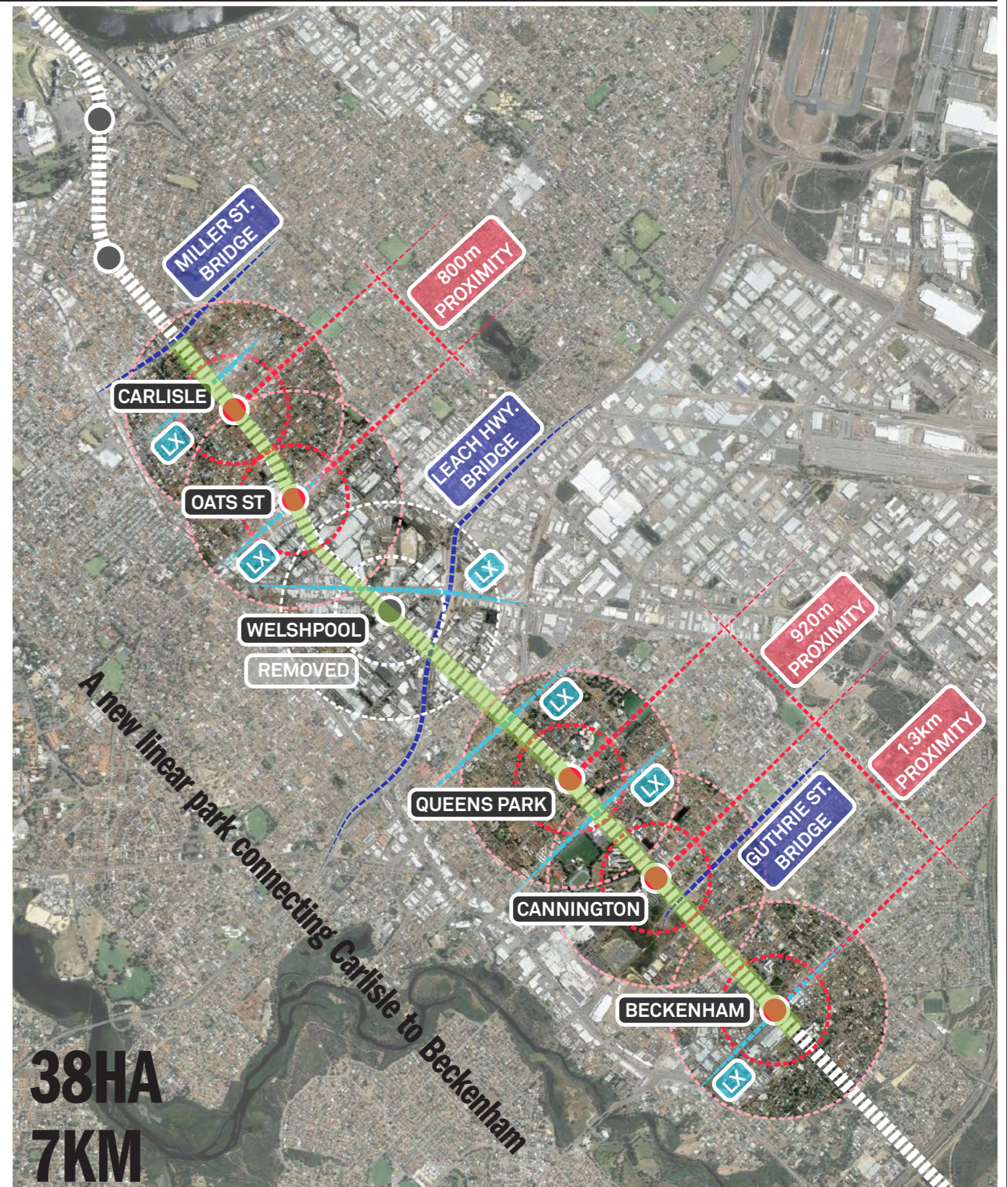

1.2 PLACE PLAN - QUEENS PARK STATION

PLACE PRINCIPLES

The Queens Park Station Final Place Plan has established the following Specific Place Principles to address the urban form of the precinct. The design has been formed by these Place Principles.

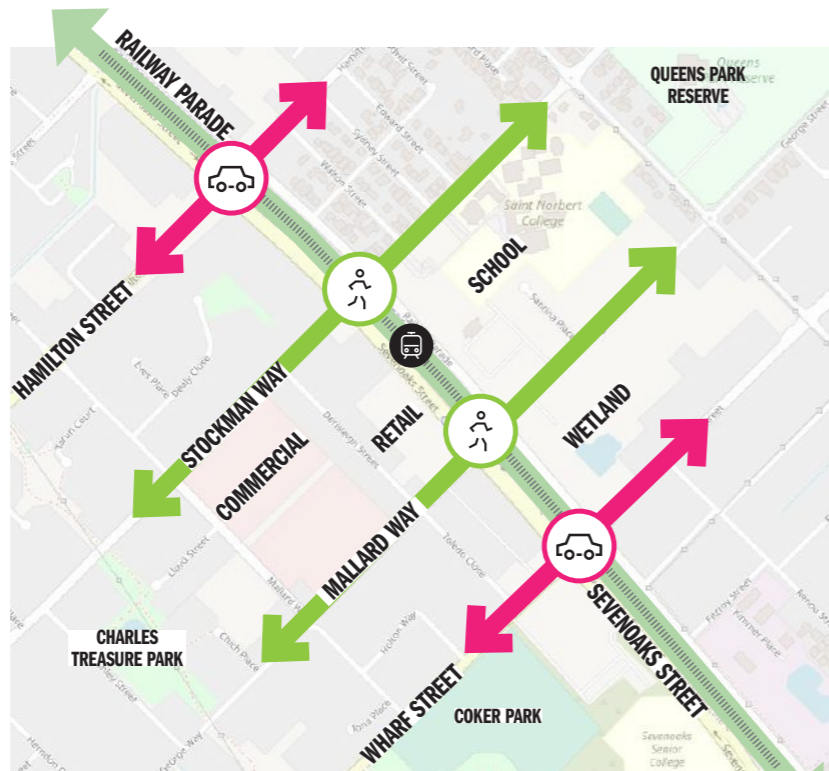

NEW NORTH TO SOUTH CONNECTIONS
Simpler, safer pedestrian and vehicle connections run under the rail line. The barriers of fences and tracks are removed, and free movement is encouraged below.

This place principle has been achieved via the raising of the rail and provision of a considered pedestrian and vehicular circulation network - refer "Access and Circulation" page for further details.

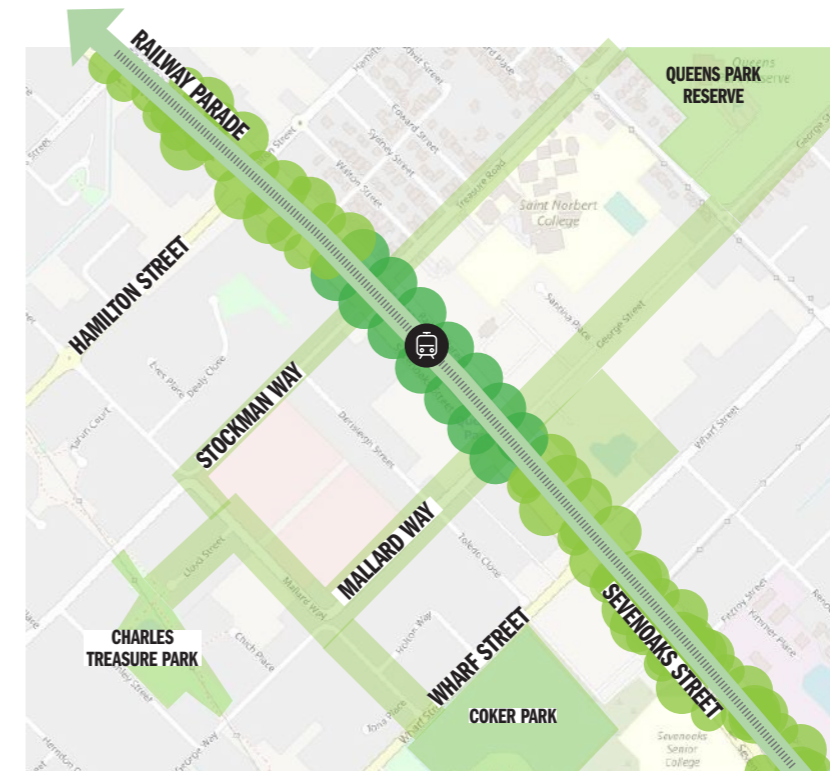

BRINGING SHADE AND GREEN TO THE RAIL CORRIDOR AND BEYOND
Green connections from north and south are strengthened and brought into the core of Queens Park's station environment. Double lined tree edges and passive spaces run alongside and under the rail.

Each train station has a unique signifier tree species to respond to the Cultural Narrative across the corridor and highlight the specific character of this environment and place.

This place principle has been achieved via the creation of planting strategy to green the corridor with native and identifying tree species, under storey and ground covers. This strategy is further explained within the Wharf Street PDR.



A NEW COMMUNITY MEETING PLACE
A new place for Queen's Park that brings together the rich cultures and age groups that use the station. It brings together north and south neighbourhoods, with flexible spaces that can host events.

This place principle has been achieved via the creation of several different community amenities such as a large station plaza with adjacent lawn for community events and markets, a community gathering area close to the Water HQ with banquet tables and barbecue facilities, a youth plaza and playground area as well as informal seating nodes. All these amenities provide the community opportunities to meet and come together.

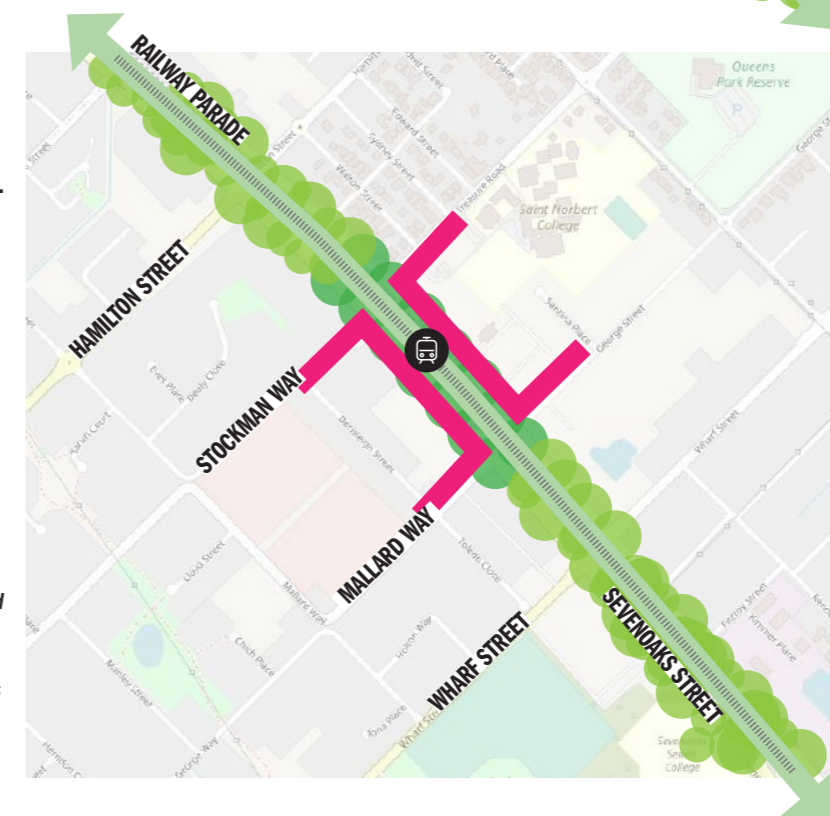

CREATING STRONGER URBAN EDGES AT THE CORE
Planning frameworks and infrastructure upgrades prioritise the conditions for existing sites facing the rail line to redevelop and open active edges onto public spaces under and beside the rail.

This place principle is identified as a future opportunity that has been supported by the current landscape design. The placement of the Queens Park Station and associated forecourt allows for future development of active edges and potential for linking plazas and permeable edges interfacing between the corridor and surrounding built form.

LANDSCAPE OPPORTUNITIES

The following are the landscape opportunities that were identified within the Queens Park Place Plan.

Opportunities 1 - 4 have all been included within the Concept Design (following page).

Opportunities 5 and 6 are outside of the project boundary and are therefore not included within the current scope but are also not precluded from happening in the future.

1. STRONGER CONNECTION NORTH-SOUTH

Clear and well shaded crossing points and footpaths facilitate safe movement for pedestrians to move north-south across the rail corridor to the adjacent neighbourhood.

2. DESIGNED WITH KIDS IN MIND

The public realm around the station caters for the surrounding school children, offering safe spaces for both old and young children to play before and after school in the form of informal nature play and a dedicated playground.

3. COMMUNITY ORIENTED PARKLAND

Queens Park's cultural diversity makes it inclusive and lively. Its evolving urban centre delivers new public places, bringing different neighbours together to share and celebrate rich aspects of community life.

4. CELEBRATE WATER

Opportunity to integrate best practice Water Sensitive Urban Design and recognise and celebrate the wider drainage catchments of the Canning floodplain. Interpret local water courses and drainage networks through the concentration of vegetated drainage basins and swales within the parklands that demonstrates best practice water sensitive urban design.

5. ENHANCED URBAN FOREST

Opportunity for extensive tree planting in the surrounding neighbourhood to benefit urban cooling, shade provision and urban biodiversity.

6. SHARED ZONE INTERFACE TO STREETScape AROUND STATION

Opportunity to reduce vehicle speeds through a shared paving zone which will provide clear and safe connections to surrounding schools and shopping precincts on both sides of the train line. This could be delineated through a different paving surface colour and texture.

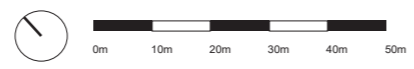

TRAIN STATION	FORECOURT & ENTRANCE	COMMUTER PARKING	DROP-OFF PARKING	PRINCIPAL SHARED PATH	MULTI-USE PLAZA	COMMUNITY MARKETS	SKATE PARK	KIDS PLAYGROUND
SHARED ZONE ACTIVE INTERFACE	COMMUNITY NODE	EXERCISE HUB	COMMUNITY LAWN	NEIGHBOURHOOD CONNECTION	WATER COURSE INTERPRETATION	STATION SIGNIFIER TREE PLANTING	MIXED ENDEMIC TREE PLANTING	URBAN FOREST ENHANCEMENT

1.3 PLACE PLAN - CANNINGTON STATION

The Cannington Station Final Place Plan has established the following Specific Place Principles to address the urban form of the precinct. The design has been formed by these Place Principles.



STRONGER CONNECTIONS ACROSS THE TRAIN LINE

As active transport hub and transfer station, legible and clear connections are vital for ease of transfer. Water in the landscape is used as a wayfinding device to link people to the town centre and nearby water bodies.

This place principle has been achieved via the raising of the rail and provision of a considered pedestrian and vehicular circulation network and the legible location of the station on the Cecil Ave axis.

The pedestrian connectors through drainage basins and zwale routes along with proposals for Gibbs St are identified as a future opportunities that have been supported by the current landscape design.

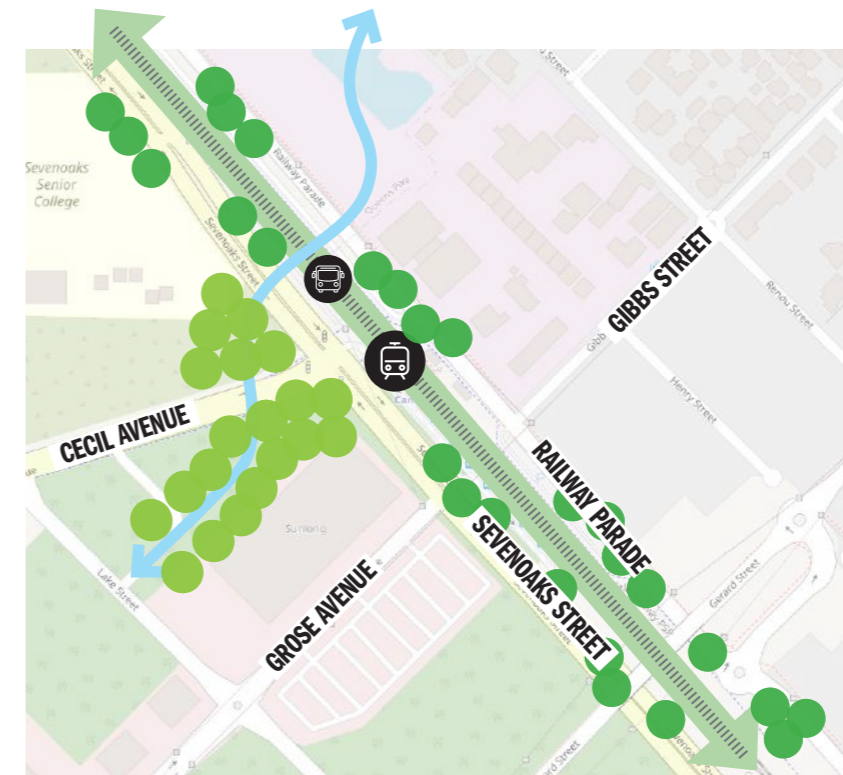

GREEN AND BLUE ECOLOGICAL RIBBONS

Celebrating the local ecology, existing mature trees and waterways across the precinct. The enhanced green space will provide an improved pedestrian experience and connect to the surrounding landscape.

This place principle has been achieved through increased tree canopy coverage along the corridor, the use of native planting.

The waterway crosses through the bush-hub location and will be recognised and celebrated via large rain gardens in support of sustainability and Water Sensitive Urban Design outcomes.

Interpretation opportunities are to be explored within the art strategy.

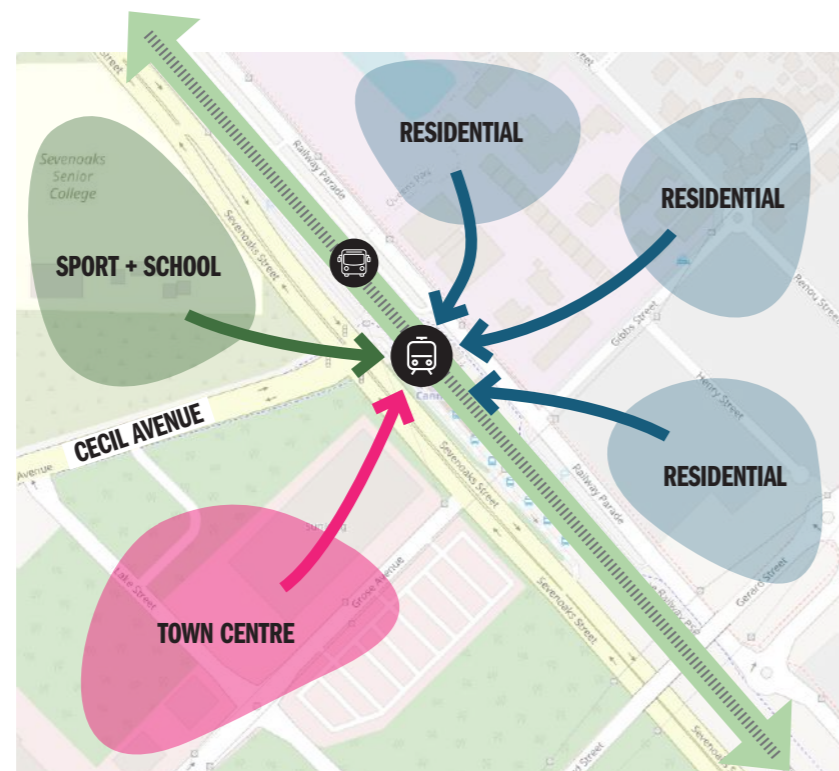

COMMUNITY THREADS WEAVING INTO A CENTRAL HUB

Connecting community hubs by creating a public stage and platform for social engagements and interactions. Creating spaces to bring communities together and to share public life together.

This place principle has been achieved via the creation of several different community amenities within the large station plaza including; an alfresco terrace with shade trees and seating walls. This space is located adjacent to the station tenancy space and can support a modular or temporary F&B outlets with associated loose cafe tables and chairs.

A youth zone has also been provided with bouldering walls and breakout areas.

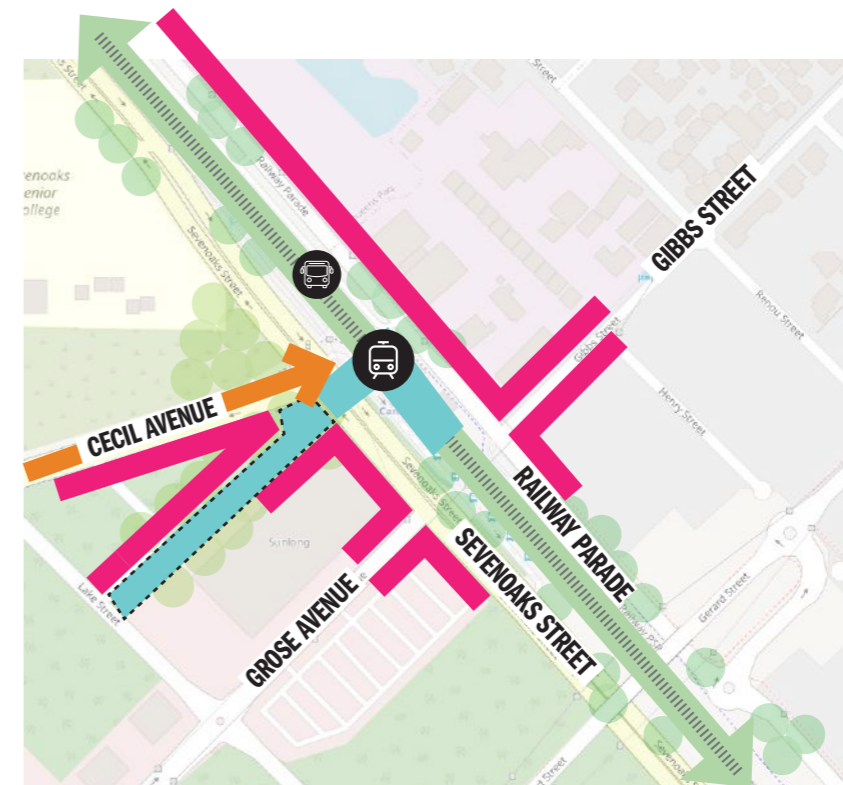

FUTURE DEVELOPMENT

The future development of Cannington looks towards activated edges of new development blocks, a public forecourt adjacent to the station and development of Cecil Ave to enhance the pedestrian connection.

This place principle has been achieved by locating the Station building on the axis of Cecil Ave, visually connecting the station to the town centre. The station forecourt has been arranged to link to future pedestrian connections proposed through the development area. The design of the Station and forecourt allows for future development of active edges and potential for linking plazas and permeable edges interfacing between the corridor and surrounding built form on all sides.

LANDSCAPE OPPORTUNITIES

The following are the landscape opportunities that were identified within the Cannington Place Plan.

Opportunities 1 - 5 have all been included within the Concept Design (following page).

Opportunities 6 are outside of the project boundary and are therefore not included within the current scope but are also not precluded from happening in the future.

1. STRONGER CONNECTION TO CANNING STRATEGIC CENTRE VIA CECIL AVENUE

The Station building should become an architectural landmark at Cecil Ave and Sevenoaks St with associated public realm spaces that provide a visual and direct pedestrian link from the train station to the Canning Strategic Centre, Cecil Avenue being the City Centre's 'Main Street' future mixed-use development.

2. STRONGER CONNECTION NORTH-SOUTH

Clear and well shaded crossing points and footpaths facilitate safe movement for pedestrians to move north-south across the train line to the adjacent neighbourhood.

3. SCHOOL CONNECTIONS

Provision for safe pedestrian links to the train station, bus interchange and youth zones to accommodate school children.

4. INTERPRET A WETLAND

Opportunity to interpret neighbourhood water courses and water crop assets into vegetated basins within the parkland that demonstrates best practice water sensitive urban design and link to works completed by City of Canning to Lake Street Urban Stream. Interpretation opportunities are to be explored within the art strategy.

5. GIBBS STREET CONNECTOR

Create a strong pedestrian connection at Gibbs Street to support the City of Canning's Safe Active Street works. Opportunity to provide a community node within the corridor to support this crossing point with public amenity.

6. ENHANCED URBAN FOREST

Retaining the majority of existing mature trees where possible and plant new endemic trees to enhance sense of place. Opportunity for extensive tree planting in the surrounding neighbourhood to complement existing trees to benefit urban cooling, shade provision and urban biodiversity.

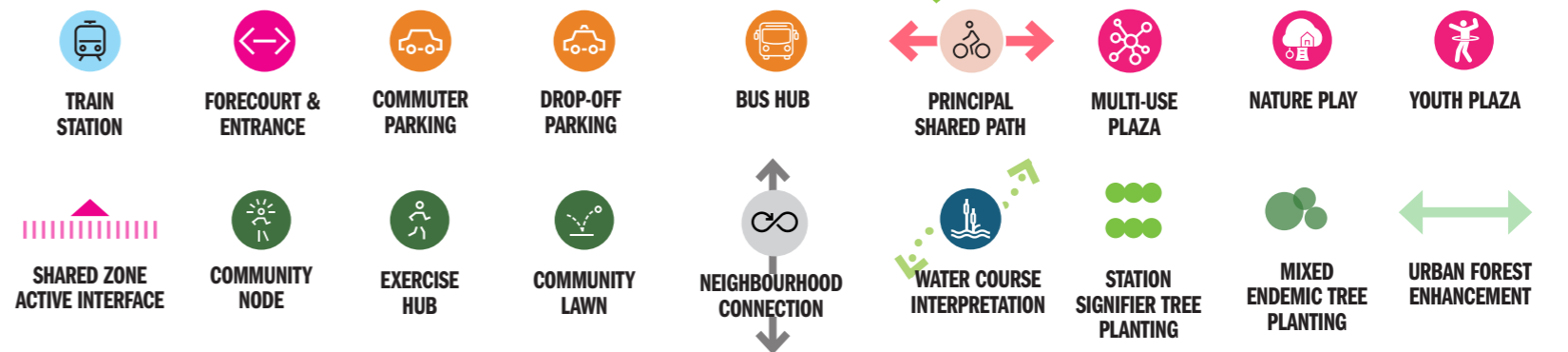
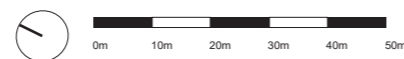
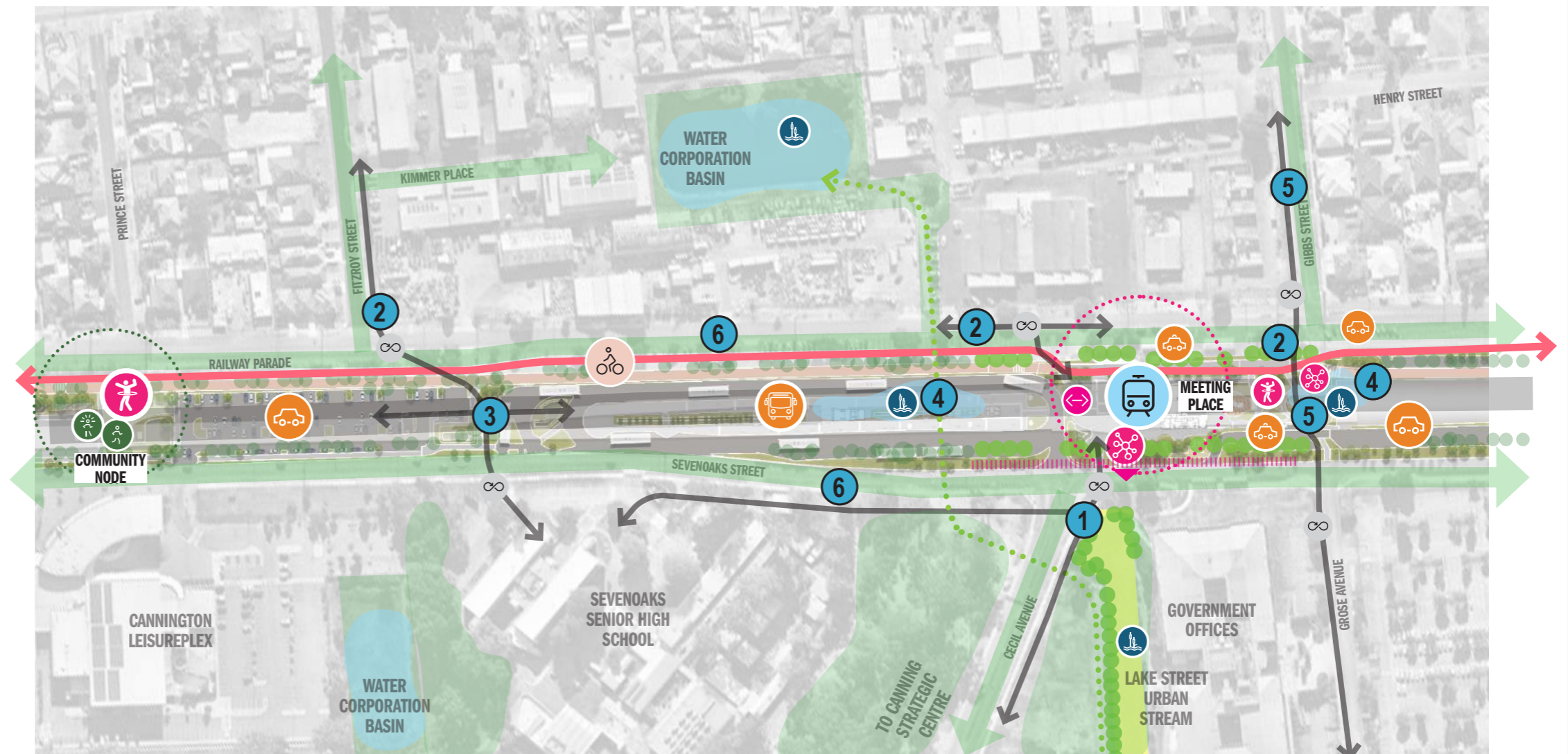

02 DESIGN PRINCIPLES

2.1 VISION

More than a rail project. Creating exceptional places for people.

Together creating a new benchmark for people, place and transport now and into the future.

The project vision is built on guiding design principles



Supported by a strong local cultural narrative

COLLECTIVE
CONNECTED
SPECIFIC

Energy of Country - Revitalising living Country through an abundance of energy, life and water.

Connection to Country - People's connection and relationship with Country - Country holds lore, customs and language.

Celebration of Place - Recognise cultural themes associated with place - ancient, historical, plants, animals and spirituality.

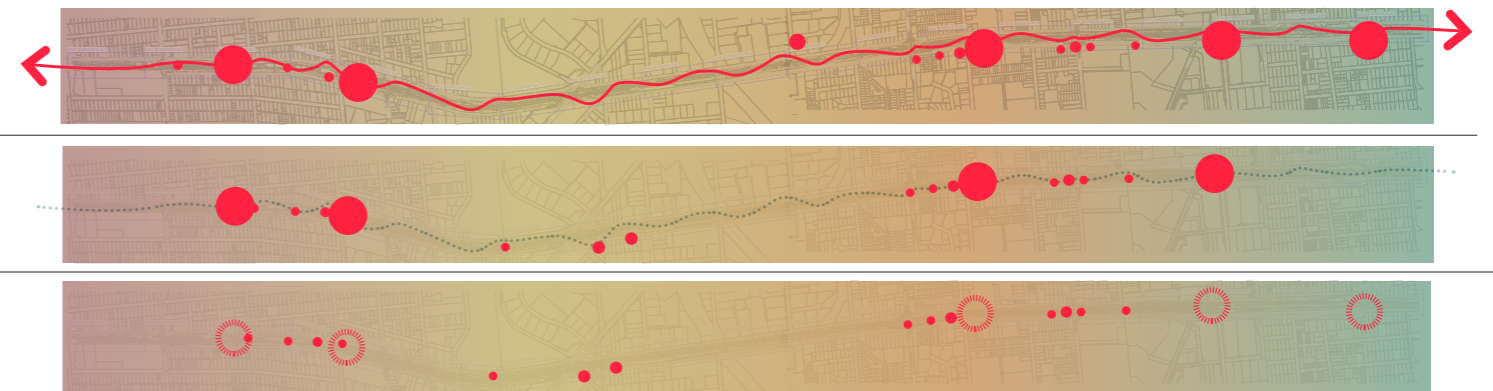

2.2 LANDSCAPE AND URBAN DESIGN PRINCIPLES

Application of Design Principles

The design has integrated the design principles adopted in the Final Place Plan. These principles build upon the overarching project strategic drivers and integration of project objectives and specifications.

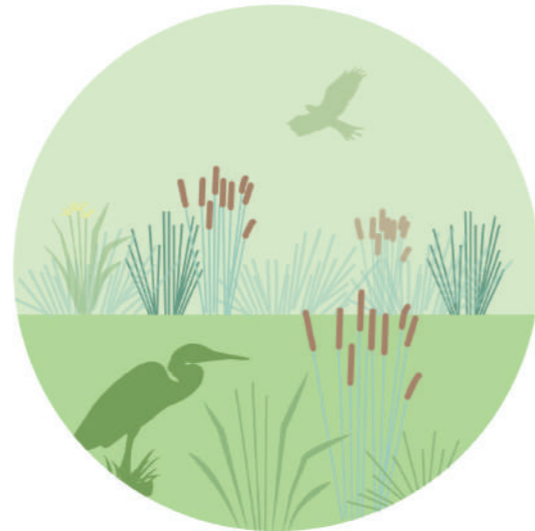

Enhance Sustainability

The design response must enhance sustainability through the following principles:

- Create extensive areas of rehabilitation planting based on the Bassendean, Cannington and Guildford vegetation complexes
- Create habitat and re-wilding opportunities for native fauna including insects, reptiles and birds
- Provide the community the opportunity to connect with nature, and green space reinforcing health and well-being.
- Integrate storm water natural systems to retain and treat water on site in a thoughtful and explicit way utilising best practise WSUD principles
- Retain as many existing trees as possible and reuse all felled timber on site (for mulch, habitat logs and nature play opportunities etc).
- Utilise water wise planting and focus irrigation to primary and high use areas such as stations and activity nodes.
- Develop best practice soil profiles that reduce importation of materials, retain moisture and minimise irrigation.
- Interpret natural systems such as water courses where possible.
- Consider whole of life costs throughout the project process and utilise robust materials that are sourced responsibly.



Reinforce Identity

Through a process of community consultation the design is to identify a precinct approach that will:

- Develop a detailed site wide design narrative that responds to the Preliminary Place Plan framework of Collective, Connected and Specific, the METRONET Noongar Cultural Context Document and the METRONET "Gnarla Biddi - Our Pathways" Strategy.
- Implement an engagement strategy with the community, traditional owners and stakeholders to ensure stories and narrative are developed appropriately.

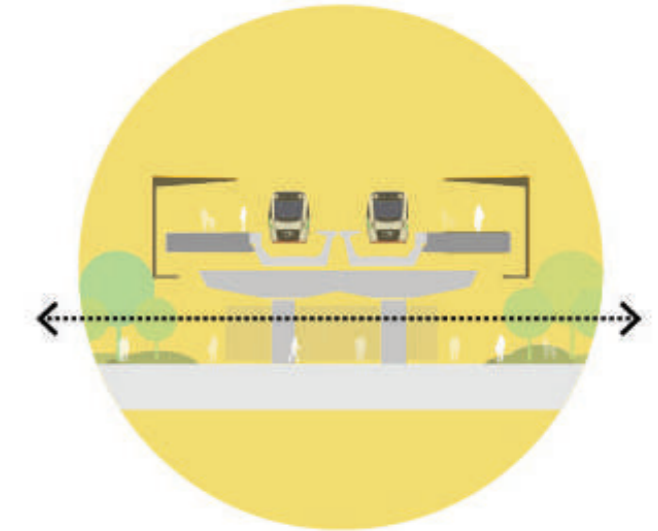

Encourage Connections across the rail corridor

The design response shall provide cross corridor connections through the following principles:

- Create generous user friendly station plaza's with high level of pedestrian and user permeability.
- Provide pathway connections across the corridor at intersections with adjacent streets.
- Provide clear direct movement paths to link adjacent community facilities, parks and services.
- Create visual and physical permeability across the rail corridor allowing intuitive wayfinding.
- Facilitate and retain natural water crossings and swales where possible.

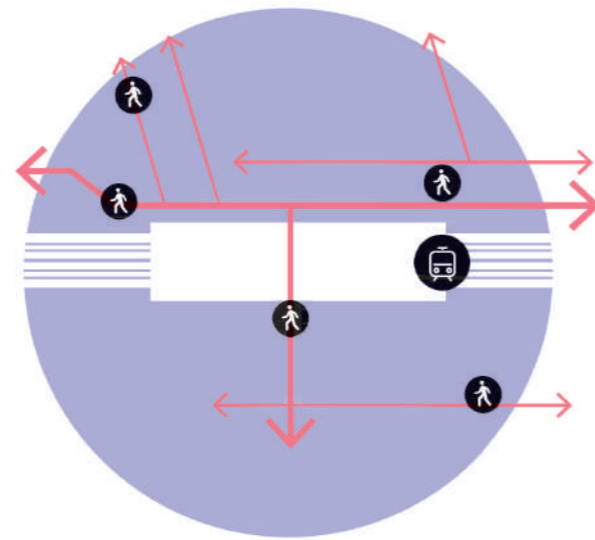

Connect Community

The design response is to connect communities through the following principles:

- Provide clear and direct movement paths between stations and associated transport modes.
- Create connecting pathways linking key roads, destinations and future developments.
- Create appropriate and focused community activation nodes adjacent to associated community uses. Such as youth plazas adjacent to Secondary Schools, play grounds near junior schools and Day Care facilities.
- Facilitate flexible community spaces and facilities for programming and activation.
- Provide a range of spaces that accommodate different users and numbers from small intimate spaces to social gathering areas.

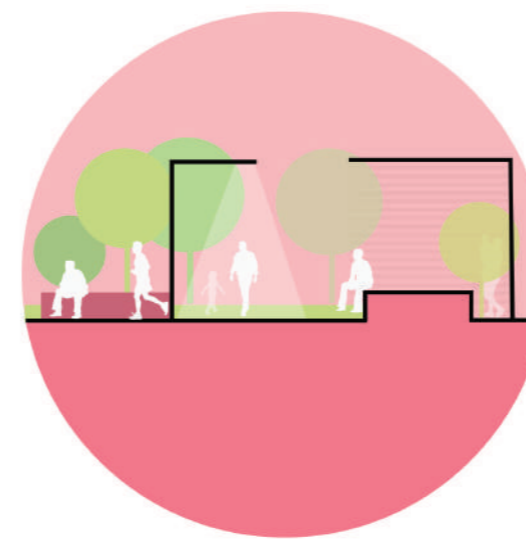

Create Safe and Comfortable Spaces

The intent is for the design to create safe spaces where people will wish to dwell and enjoy through the following principles:

- Reduce heat load through the retention of existing mature trees, the increase of canopy and understorey planting across the site and the retention of water via WSUD best practice.
- Provide shade and shelter across key areas of the site, in particular dwell spaces and activity nodes.
- Concentrate activity nodes near existing tree canopies and under viaduct for instant shade.
- Create neighbourhood walking loops for different walking distances to encourage activity for all ages and ability.
- Provide seating as rest points at intervals along all pathways.
- Provide universal access and furniture across the site.
- Provide two shared paths to separate user speeds and mitigate conflict.
- Provide natural surveillance to minimise antisocial behaviour.
- Ensure adequate lighting within nodes, plazas and pathways.
- Create defined spaces and ownership boundaries.
- Provide clear pathways and access points

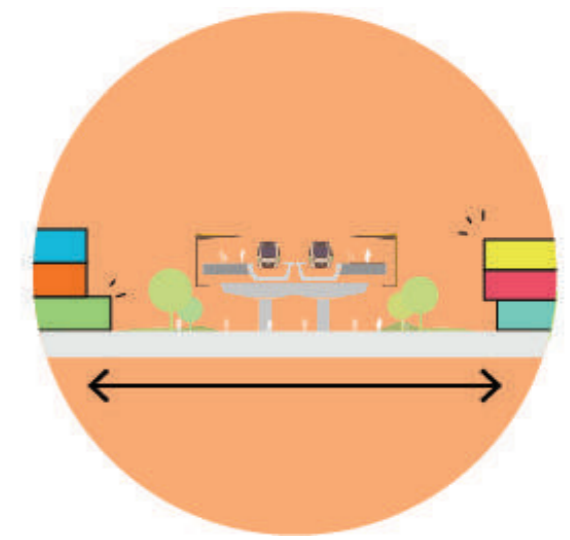

Promote Activation and Development

The design will support activation and development through the following principles:

- Create high quality public realm and landscape spaces that complement adjacent community uses and neighbourhood centres.
- Provide links or flexibility for future connections to potential development sites and anticipated adjacent uses highlighted within local structure plans.
- Ensure future proposed road crossing points are facilitated for within the landscape design.

03 DESIGN NARRATIVE

3.1 DESIGN NARRATIVE OVERVIEW

Narrative Framework

Narrative Framework

The design narrative provides an overarching theme with sub-themes for all aspects of the project. The narrative is a way to knit together the different elements of the precinct including station architecture and built form, public realm and public art, points of connections and future opportunities.

The conceptual connection has provided thematic inspiration for design decisions while leaving enough freedom to respond with the uniqueness and individualism of local place outcomes.

The Gnarla Bidji Strategy explains the METRONET "Our Pathways" approach which is created to connect places, people, families and relationships. That overarching approach has informed the project design framework which drills down into the places and stations within the project. ALUA has refined that approach one step further to further refine a narrative framework that is based on:

- Energy of Country
- Connection to Country
- Celebration of Place

Those thematic gestures have been identified as culturally, environmentally, and socially significant to the METRONET Armadale project. The ALUA Cultural interpretation strategies are sub-themes that invite future opportunities for deep storytelling, healing, revealing, celebrating, and truth telling.

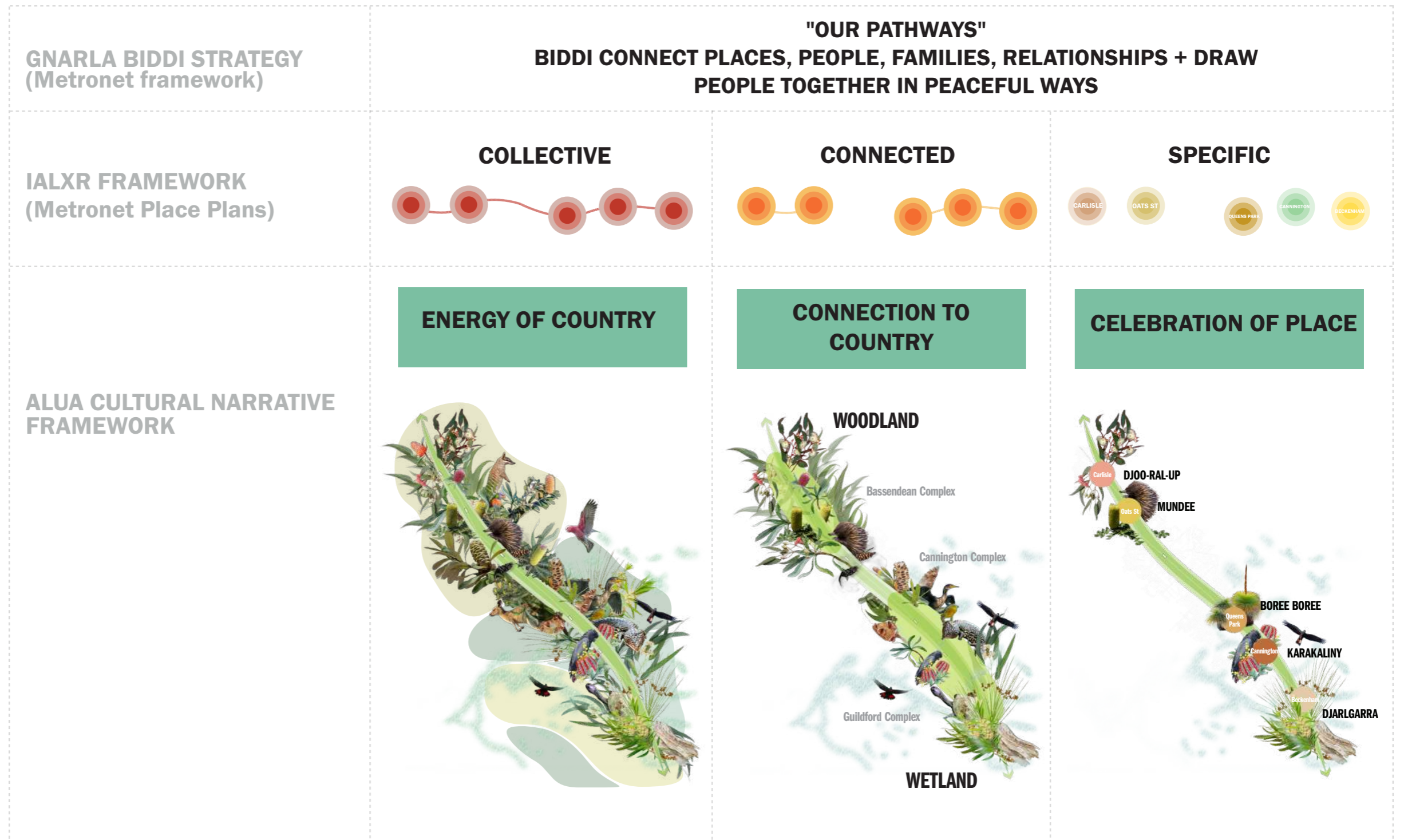

3.2 COLLECTIVE ENERGY OF COUNTRY

Canning River - Djarlgarro Beeliar
 Noongar meaning - 'Place of Abundance'

UNDERSTANDING LIVING COUNTRY:

_Dominant Plant Communities

_Geological Boundaries

_Mapping Water Systems

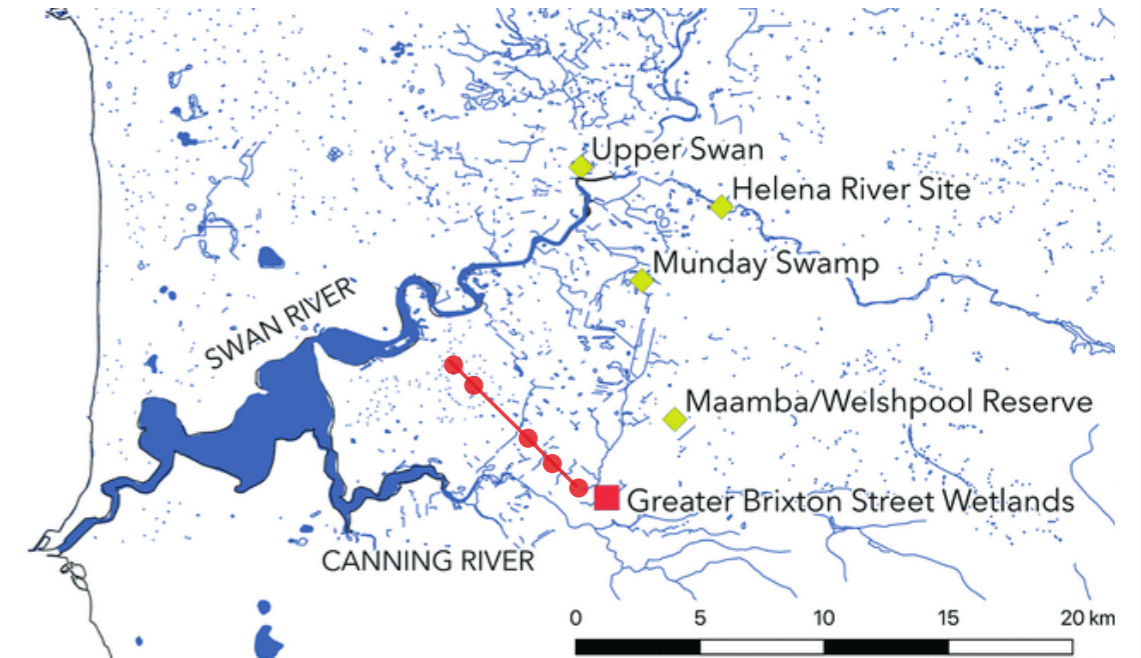

Carly Monks, Location of archaeological sites from the Swan Coastal Plain and Darling Scarp (Monks, 408)

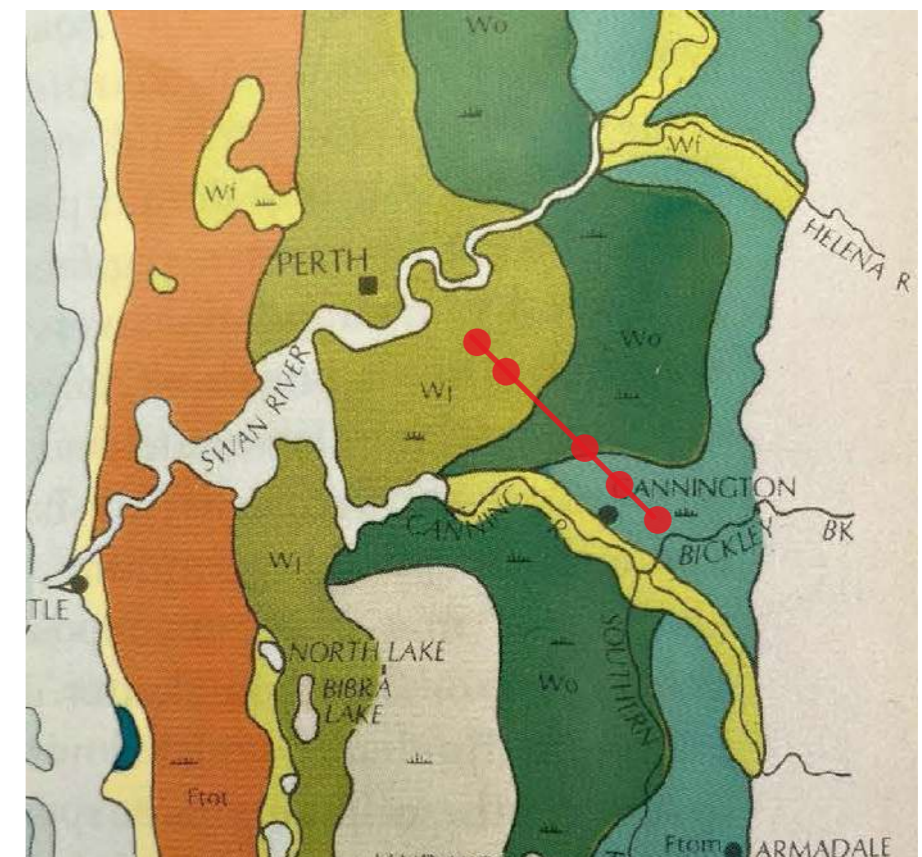

Plant formations in the study area (Seddon, 158)

Coming Together to Celebrate the Energy of Country

REVITALISING LIVING COUNTRY:

_Energy and Abundance of Life

_Energy and Abundance of Water

_Respecting and Symbolising the Energy of Country

Linewide Strategies - "Energy of Country"

- Six Seasons Planting utilising plant species from the original vegetation complexes.
- Re-wilding - encourage life back to the corridor (insects, reptiles and birds)
- Reinstate natural ecosystems - water treatments, basins and streams

Key Interpretive Strategies - "Coming Together"

- Celebrate Kambarang through wild-flower planting (Kumbar meaning 'big' or 'large' referring to large number of people coming together for social, ceremonial and economic purposes.)
- Mass plant Banksia to celebrate mungyte flowering season and represent the tradition of coming together.
- Spiritual energy through abundance of life and concentration of living energy.

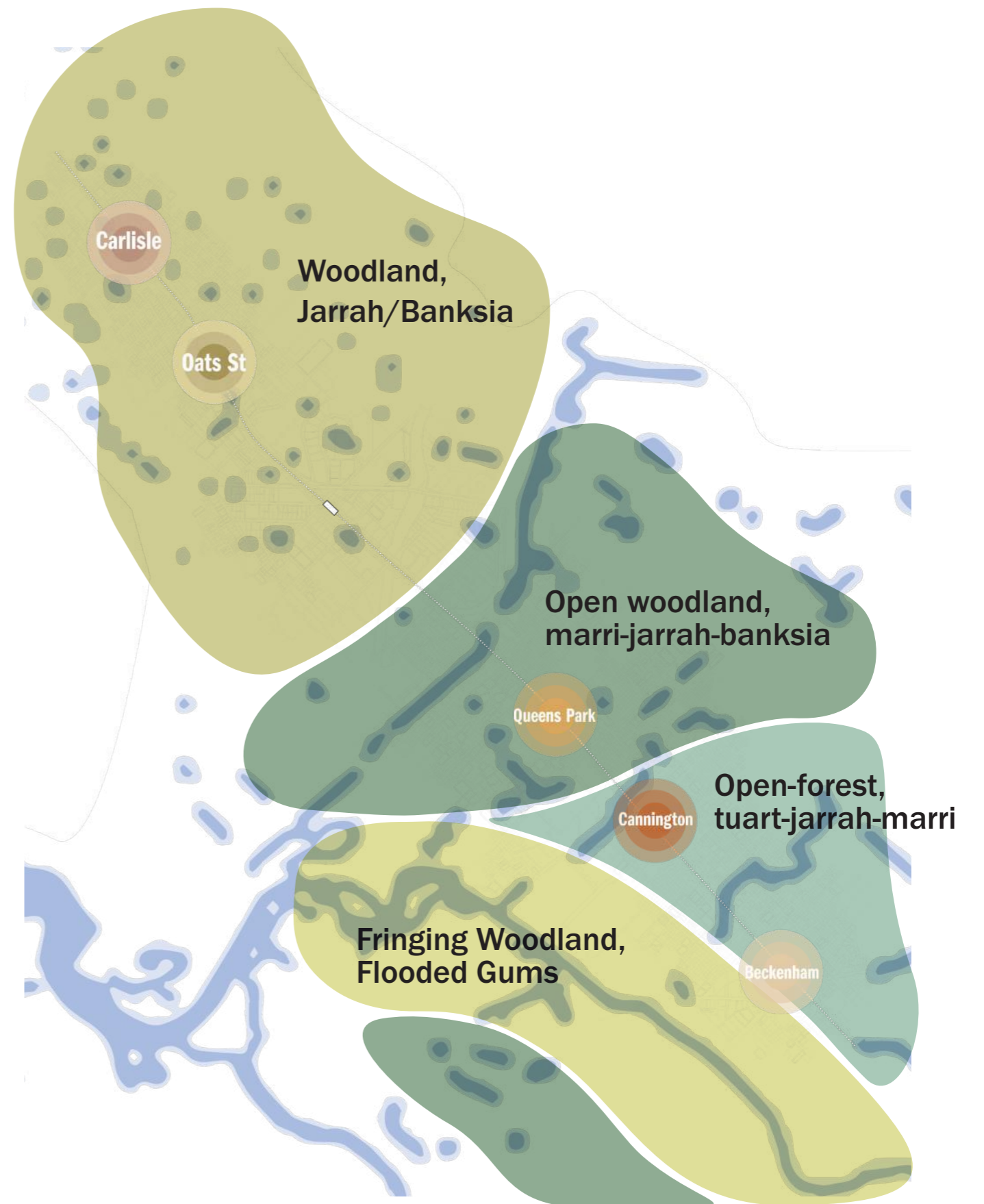

3.3 CONNECTED_CONNECTION TO COUNTRY

Coming Together to Celebrate the Energy of Country

CONNECTION TO COUNTRY:

- _Noongar Whadjuk People's connection to Country
- _Traditional Activities (Deep Timetable)
- _Traditional Noongar Whadjuk Clan Lands
- _Custom, Lore + Language

Woodland and Wetland

- Two different geological and plant formation types.
- Woodland to the north and open woodland to the south.
- Small watering holes to the north and larger rivers, creeks, watering holes and wetlands to the south

Beeloo and Beeliar

- Two great Whadjuk Clans - Beeloo and Beeliar
- Beeloo considered the land north of the canning river part of their ground while the Beeliar mainly traversed the southern section of the river to the sea.
- It is here at the Canning River that the Youran (bobtail lizard) meets the Nyingarn (echidna).
- Youran - totem animal for the Beeliar people
- Nyingarn - totem animal for the Beeloo people

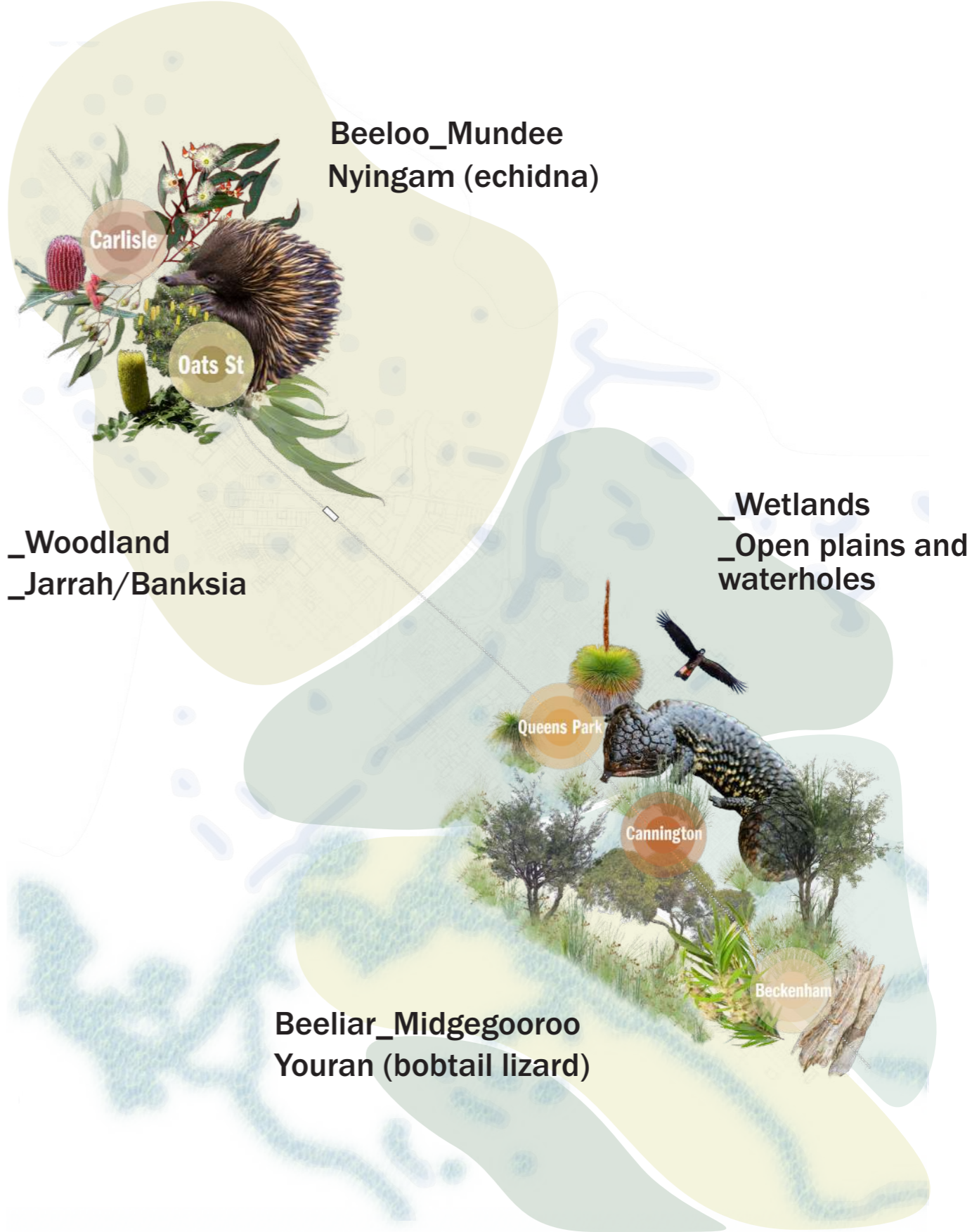

3.4 SPECIFIC CELEBRATION OF PLACE

Carlisle

DJOORALUP

As referenced on the Department of Local Government, Sport, and Cultural Industries Gnarla Boodja Mili Mili project, Joorolup is the traditional name closest to the Carlisle train station. It comes from the Djooro or jarrah and is the totem of the Djooral Kalla which is the clan group who governed the region. Djooralup the place of the djooral (jarrah).

Djoo-ral-up

Place of the Jarrah Tree



Oats St

MUNDEE

Upon the arrival of the British in 1829, Mundee the Noongar leader governed the land of Beeloo as the tribal leader of the Djooral Kalla (Djeeral) clan. Mundee's Kalla or clan of 32 persons was identified. The Elders approved the use of Mundee to promote the heritage and history of the region and gives recognition to the Noongar leader of the Beeloo territory.

Mun-dee

Noongar leader of the Beeloo territory

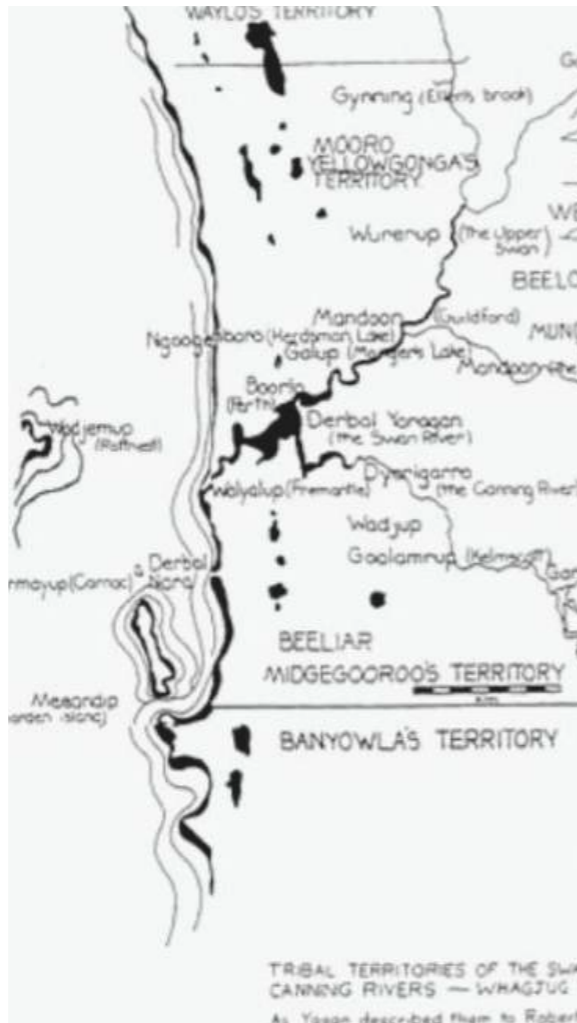

Queens Park

BOREE BOREE

Boree Boree is the flat plain surrounding Queens Park region and it is referenced by Bates 1992 as being the land governed by Joobaitch a prominent Noongar leader. Flat plains were often used to drive animals into the open to hunt which made it easier to catch them. Bor-ee Bor-ee, the great mass of land or large flat plain.

Bor-ee Bor-ee

Great mass of land or large flat plain



Cannington

KARAKALINY

Cannington has been well known by many Noongar people as the Karakaliny (Karragullen) due to the number of red tail cockatoo that frequent the area. The verification of the name of Karakaliny was provided through consultations with Elders who had the knowledge passed down from generation to generation. Karak is the name of the red tail cockatoo and due to the number of red tail cockatoo in the area the local Noongar call this place Karakaliny, the place of the red cockatoo.

Karak-al-iny

Place where the red tail cockatoo moves



Beckenham

DJARLGARRA

Djarlgarra is the traditional name of the Canning River, a significant place due to its association with the Waagul or rainbow serpent. Interviews with Elders validated the need to protect and promote the traditional names and dreaming of the water ways. Beckenham station is the closest station to the Canning River and will promote the traditional name of Djarlgarra to educate the community. Djarlarra the place of abundance.

Djarl-gar-ra

Place of abundance



3.5 STATION NARRATIVE

Design Narrative Framework - Stations

The linear park is a reflection of the natural world, the design bring to life a living country, it draws people into the space to create an abundance of energy and references the importance of water. The forms are fluid and natural.

The stations are a reflection of the existing materiality and architectural aesthetic of each local place along the rail line. The form is more geometric and structured responding to the urban framework.

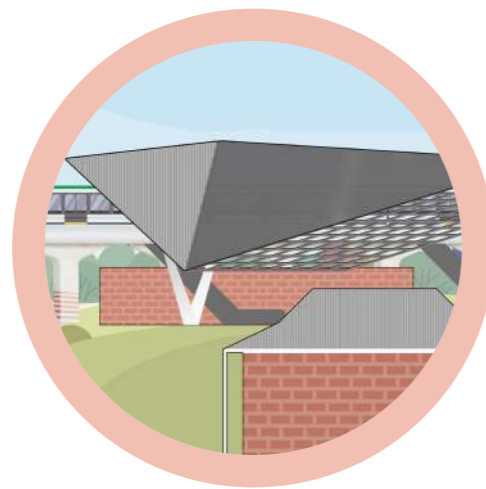
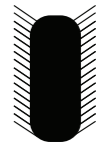

Carlisle

Inter-war Vernacular
Architecture

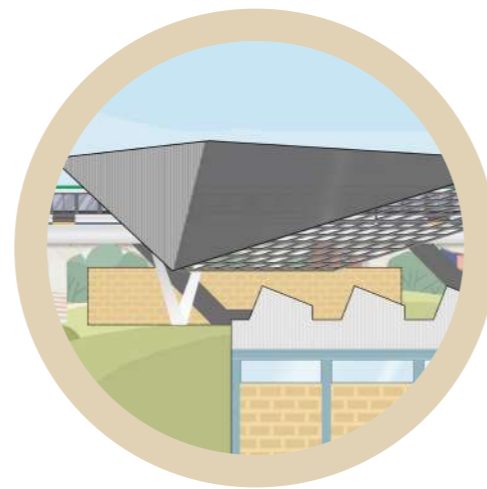

Oats Street

Technological Innovation
Education



Queens Park

Urban Grain Opening Up To
Perth Hills



Cannington

Urban Grain Opening Up To
Canning River

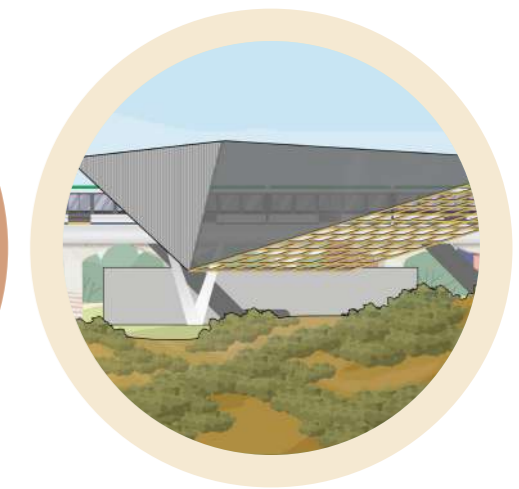

Beckenham

Perth Hills Landscape

Material Palette Adapted to Create Individual Identities



Carlisle



Oats Street



Queens Park



Cannington

3.6 STRUCTURE NARRATIVE

Interpretive Protective Markings Embodying the Concept of Travelling Safely Through Country *Part of DA 01 - Viaducts and Piers*

Integrated Design - Viaduct Screen

With indicative designs prepared by Barry McGuire, the viaduct screens reflect Noongar shield designs which are a symbol of protecting people as they travel through country, along the railway corridor and line above. The viaduct provides a connected identity and narrative along the whole corridor, with the opportunity for Noongar place names integrated with each specific station.

“These are the symbols or protection from our old shields. This pattern would have been grooved out. I’ve drawn thick lines to symbolise the deep carving of the woods. This symbol of protection wraps around the piers. It will keep everyone safe.”

- Barry McGuire

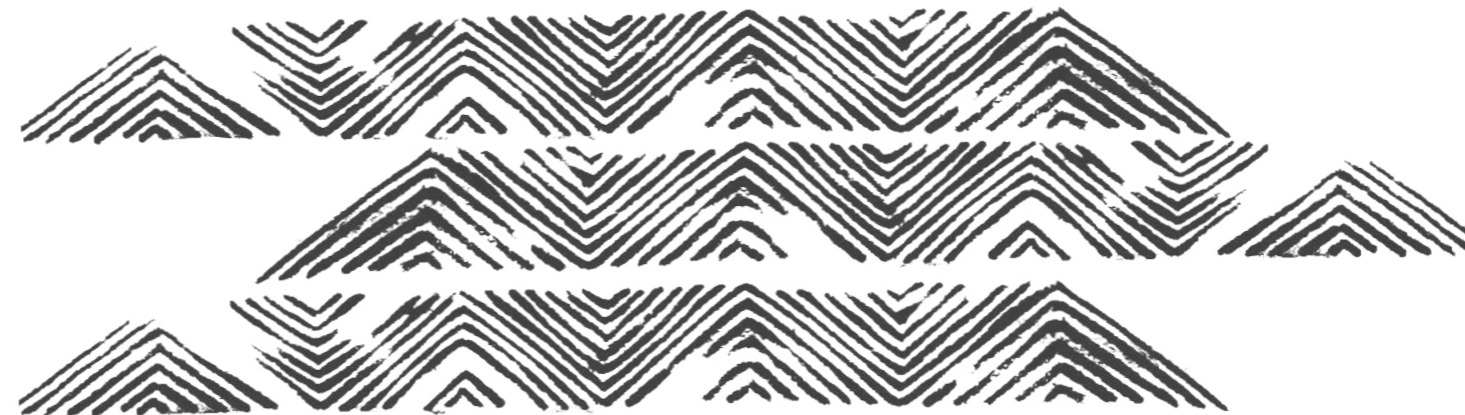

Artwork By Barry McGuire



Example of Noongar Shields



Example of Integration - Archer Street

The base artwork pattern has been adapted to fade from areas of greater to lower intensity creating a variety along the rail corridor

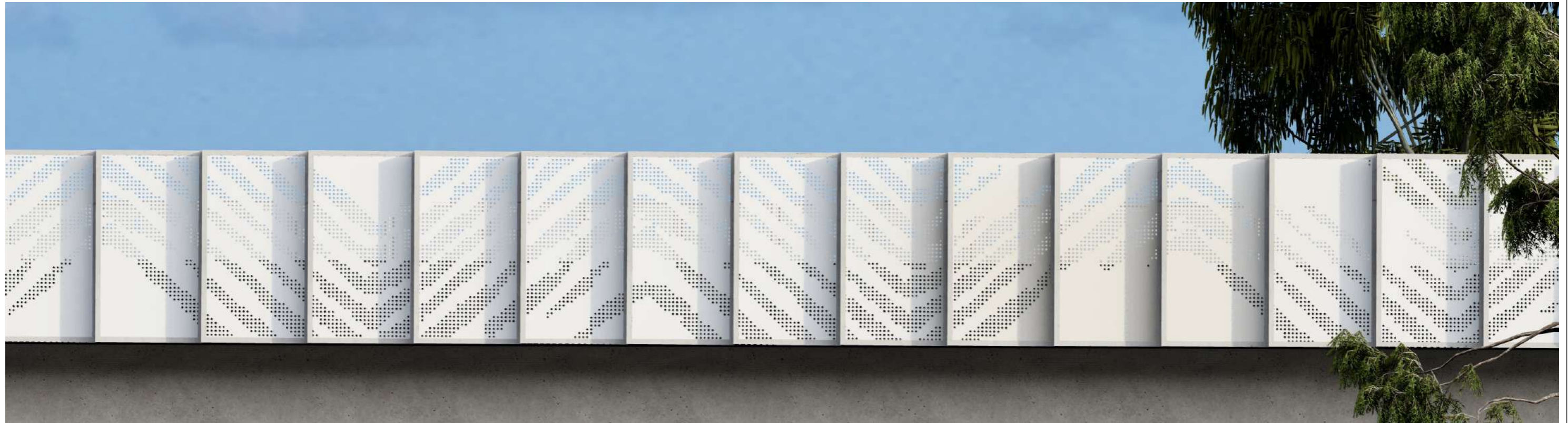

High Intensity Pattern At Stations (10% Perforate)

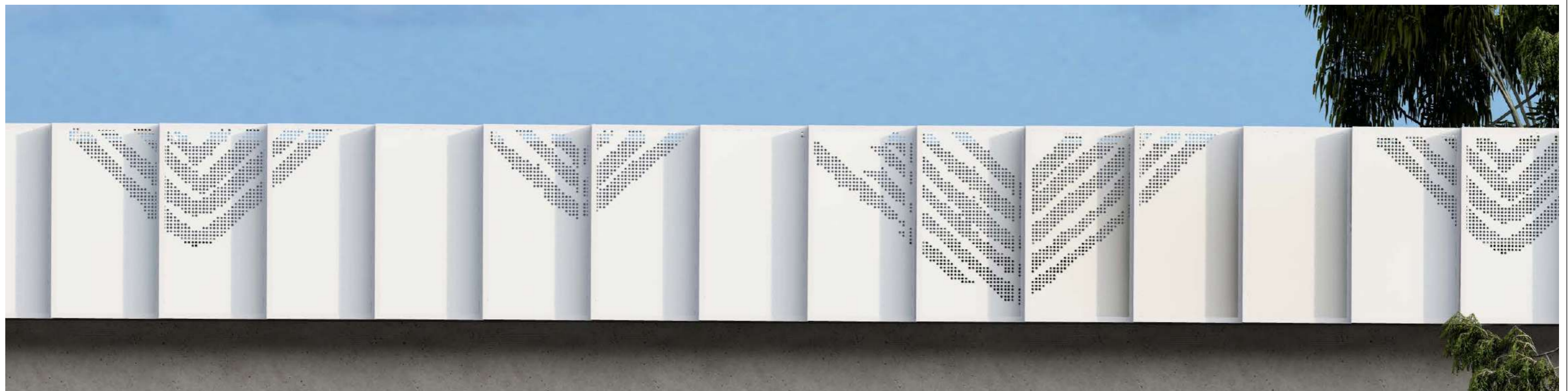

Lower Intensity Pattern Linewide (4.6% Perforate)

Part of DA 01 - Viaducts and Piers



High Intensity Twin Pattern



Interface at Station



Patten Transition at station

Integrated Cast In Artwork - 2.5m Wide Module

Part of DA 01 - Viaducts and Piers



Viaduct Screening Over Mint Street

04 DESIGN STRATEGIES

4.1 OPPORTUNITY

Creating a Linear Park

The strategy to elevate large portions of the railway along the Inner Armadale Line will achieve the goals to remove an at grade level crossings and therefore manage traffic flow and significantly improve safety and travel times in the area.

The significant opportunity this project generates through the elevation of the rail is in creating open connections between communities surrounding the railway and valuable areas of public open space.

This project seeks to provide a corridor full of life and vibrancy connecting the city to the hills that revitalises country by returning this previously inaccessible space to the community and nature.

An ecologically rich linear parkland, imbued with stories and meaningful connection to the community, to First Nations 'Country', to place and beyond.

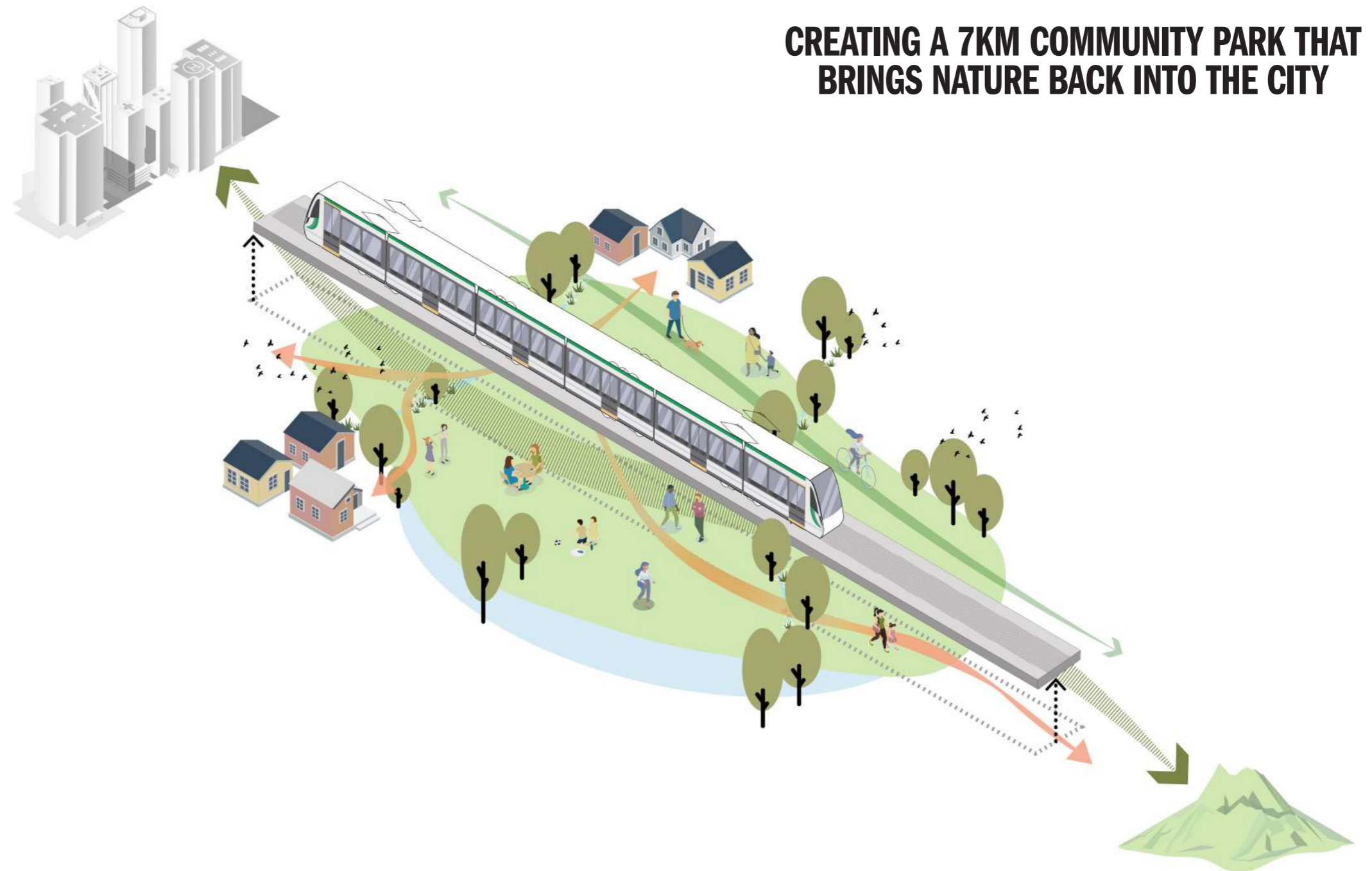

4.2 CONCEPT

Concept Design

The Metronet brief instructs that the urban and landscape design is consistent with the intent of the Preliminary Place Plan and Landscape Concept documents.

This has been achieved through key moves such as:

- Creating a vibrant linear park with a range of community facilities, attractions and flexible spaces.
- Opening the cross connection of the corridor via safe and well defined pedestrian pathways.
- Meeting the needs of multiple different local users such as families, elderly, school children, retirees, youths, young adults, workers etc.
- Creating the station plazas as arrival spaces for the neighbourhood centre, providing orientation and amenity.
- Providing community hubs with play spaces and uses focused to adjacent community facilities, school and childcare centres.
- Providing a range of seating opportunities including alfresco dining and outdoor study spaces.
- Ensuring viaduct maintenance and emergency access along trafficable pedestrian paths.

The design concept was developed to optimise opportunities to interface with adjacent urban renewal. Strategic planning context has been reviewed in all locations and the landscape has been designed to provide opportunity for further connectivity and links to future public open space and urban development.

The landscape design meets the Metronet requirements whilst offering enhancements such as:

- Consolidating key activation and amenities at station neighbourhood centres and adjacent to key destinations.
- Enabling a rhythm of character zones along the corridor between active centres and passive quieter parkland zones.
- Celebrating quiet parkland and allow space for nature, habitat, retreat and well-being.
- Increasing the overall area of pedestrian paths (above the SWTC design intent) in order to:
 - Provide two primary pedestrian paths that loop through the parkland creating a network of neighbourhood walks and trails.
 - Remove high speed cycle users from the centre of the corridor to the periphery to minimise crossing points and conflict.
- Creating a chain of small parkland nodes - seating, exercise and play creating smaller scale points of interest and activity along the corridor.
- Utilising the viaduct for shade through the location of a large proportion of nodes and activation under structure.

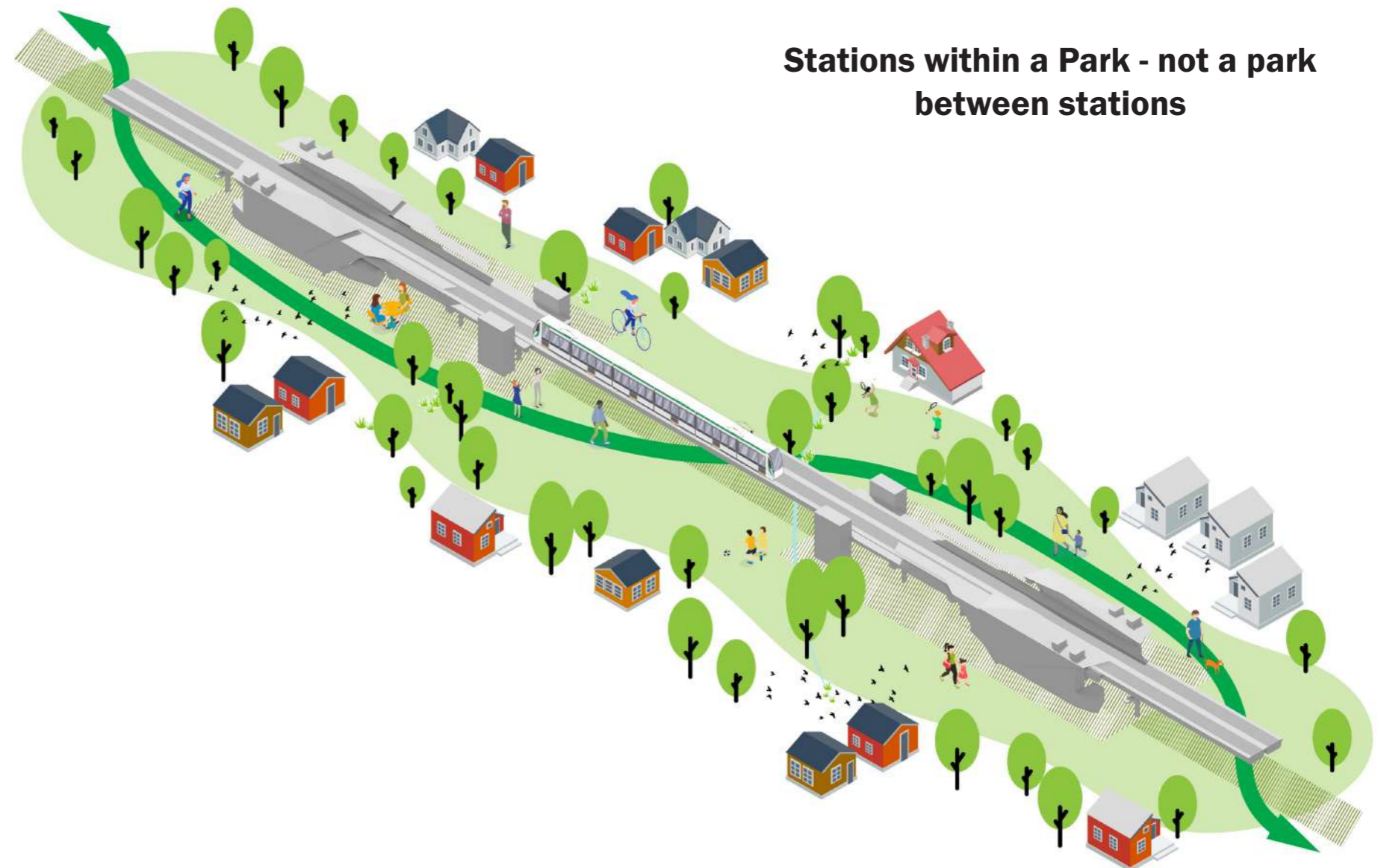

Stations within a Park - not a park between stations

4.3 DESIGN STRATEGIES

Strategies

An extensive process of site evaluation, local content understanding and engagement with stakeholders and community identified a number of important strategies that have been integrated into the design outcome:

- Cultural Narrative - provides the foundation for the design approach to this important project.
- Circulation Strategy - that provides for a nodes and loops approach and PSP strategy
- Activation Strategy - Identifying zones that support a diverse mix of activities to meet the multi-generational needs of the culturally diverse community. It will include active and passive zones, with nodes for exercise and seating.
- Play Strategy - The linear part will provide ample opportunities for play, they will include youth play, free play and divergent play.
- Universal Access Strategy - Access to the park for as many possible is essential to project success. All abilities will feel welcome to recreate in this inviting place.
- Sustainability Strategy - An integrated approach to sustainability is imbued into the project via a re-wilding approach, a native planting strategy, integrated storm water and a considered approach to irrigation.
- Public Art Strategy - fundamental to the art strategy is an integrated approach to design, wayfinding and public art.

These strategies have come together to create three strong design themes:

- _ Activation - A local place approach
- _ Environment - A re-wilding approach
- _ Movement - a nodes and loops strategy

Activation A local place approach



Application

- Local Community Spaces
- Divergent Play Strategy
- Universal Play
- Free Play
- All Ages Play
- Creative Play
- Immersive Play

Environment A re-wilding approach

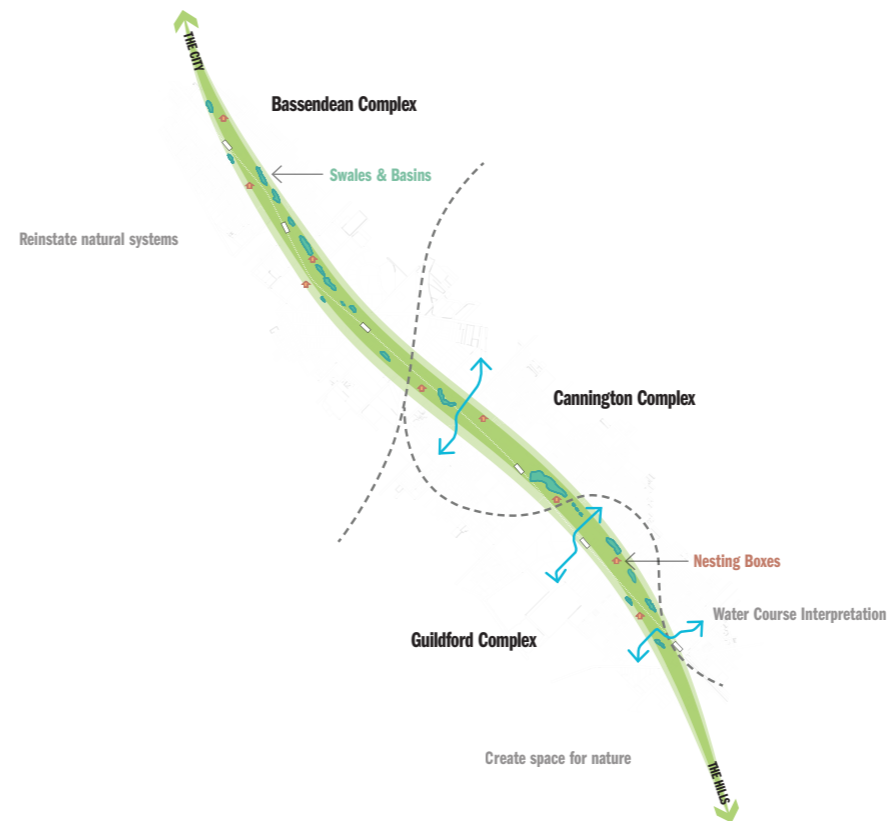

Application

- Storm water Approach
- Irrigation
- Sustainability
- Planting Strategy
- Irrigation Approach

Movement A nodes and loops strategy

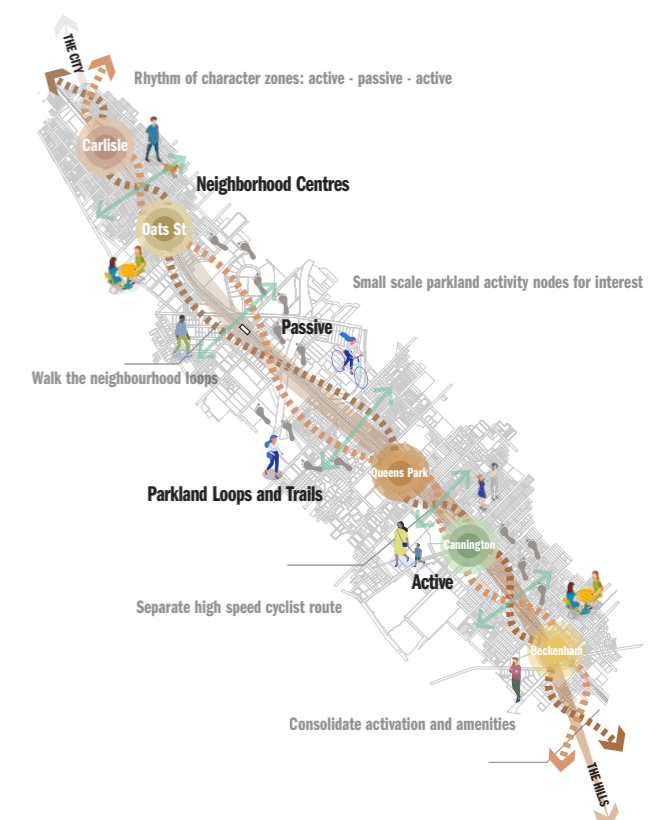

Application

- Principal Shared Path
- Universal Access & Inclusion Strategy

4.4 URBAN DESIGN APPROACH

Wharf Street Package



Legend

- Precinct Paving
- Footpath
- PSP
- Lawn
- Planting
- Infiltration Planting Beds
- Trees

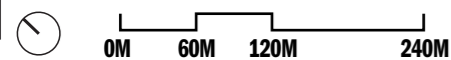

- ① Necklace of vegetated drainage basins along the length of the corridor capturing water from viaduct structures. Basins provide natural infiltration and passive irrigation of the landscape.
- ② Opportunity to draw water from the Water Corporation drainage systems to support irrigation of the landscape works and improve Water Sensitive Urban Design outcomes (to be explored in collaboration with the City of Canning and Water Corporation).
- ③ Fenced dog exercise area under the shade of the viaduct.
- ④ Areas of native endemic planting (First Plants) to support the cultural narrative and provision of an attractive community parkland whilst increasing biodiversity within the site. Re-wilding initiatives are being explored to provide habitat opportunities.
- ⑤ Principal Shared Path (PSP retained as existing).
- ⑥ Queens Park Station car park located under viaduct to take advantage of viaduct shade. Entrance off Sevenoaks St, located away from active community edges.
- ⑦ Opportunity to engage with Stolen Generation Survivors to understand if any recognition of Sister Kate's should be incorporated within the corridor.
- ⑧ Queens Park Station is located to face a plaza to the south of the building. This plaza connects to the desire lines to the IGA and future key connector.
- ⑨ Station plaza addresses Sevenoaks Street and Railway Parade allowing future opportunities to connect to adjacent active edges.

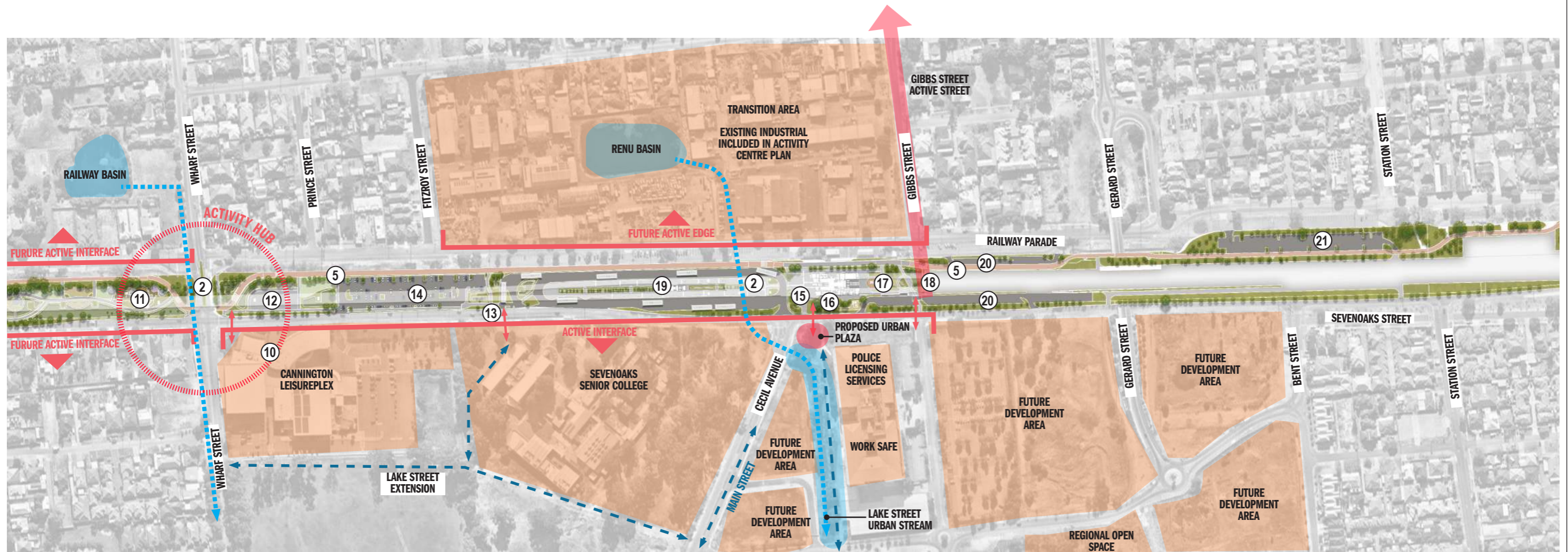

- ⑩ Creation of an Activity Hub that focuses active amenity to co-locate with the Cannington Leisureplex sharing key amenities such as toilets, cafe and car parking.
- ⑪ Community and playground spaces within current residential areas to interface with community and places of worship.
- ⑫ Youth plaza and skate park located within the Activity Hub and central to surrounding schools.
- ⑬ New connector over Sevenoaks St to allow access to Lake Street Extension and Colleges.
- ⑭ Cannington long term parking located under viaduct for shade.
- ⑮ Station forecourt and main entry aligned with Cecil Avenue.
- ⑯ Crossing location aligns with future pedestrian connector along Lake Street Urban Stream and the proposed urban plaza - Railway Square.
- ⑰ Cannington station plaza south provides activity node to support station users and community. Opportunity to provide youth activation for surrounding school users.
- ⑱ Strong pedestrian connector to link Gibbs Street Active Street across the rail corridor.
- ⑲ Bus interchange with central WSUD basins and tree planting
- ⑳ Additional long term parking close to the station.
- ㉑ Existing long stay car park - utilise within briefed long stay parking bay numbers.

05 DESIGN SOLUTION

5.1 DESIGN OVERVIEW

Design Solutions

Having established a number of informative strategies the design team has created a detailed and specific design outcome for each precinct. This design solutions relates to the complex process of balancing the design vision, scope of works, local context, design principles and those all-important strategies.

The linear park design is showcased within the following design packages:

- Oats Street Package (North)
 - Carlisle Station
 - Oats Street Station
- Wharf Street Package (South)
 - Queens Park Station
 - Cannington Station
- Beckenham Package
 - Beckenham Station

This document includes information for the Wharf Street Package only.

Across these precincts the following elements have been detailed:

- Overall master plan - highlighting the location of stations and surrounding land uses.
- Station Precincts - showcasing the nodes of activities that will be collocated with the stations

The design detail is then demonstrated across the following themes

- **Stations** - detailing the design of the station buildings:
 - State Planning Policy 7.0
 - Noongar Place Names
 - Colour and Identity
 - Brickwork
 - Platform
 - Queens Park Station Design
 - Cannington Station Design
- **Activation** - detailing where the different activities are located along the corridor from north to south including station detail
 - Railway Dog Park
 - Youran (Bobtail) Play Space

- Creekline Play Trail
- WSUD HQ
- Queens Park Community Hub
- Railway Play Space
- Cannington Youth Plaza
- Rest Nodes

→ **Environment** - detailing the environmental elements of the design including:

- Sustainability strategy
- Tree / Planting Strategy
- Shade studies and Planting Offset studies to determine the best plant allocation
- Water Sensitive Urban design Strategy

→ **Interpretation** - demonstrates the design choices made to reflect the local sense of place and the art and culture narrative including:

- Interpretation Opportunities
- Material Strategy
- Park Shelters

→ **Movement** - a series of design solutions to support all forms of movement with a priority for pedestrian movement and safety:

- Movement Strategy
- PSP Crossing Strategy
- Specific Access Plans for Station Precincts
- Security and CPTED Strategy
- Lighting Strategy

The design has been informed by:

- Extensive engagement with the local community
- Design refinement with LGA and OGA
- A collaborative design and refinement process with state government agencies
- Detailed consultation with the PTA on key issues

THEMES:

STATIONS



ACTIVATION



MOVEMENT



INTERPRETATION



ENVIRONMENT



5.2 MASTER PLAN & STATION PRECINCTS

WHARF STREET PACKAGE (SOUTH)

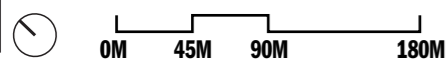
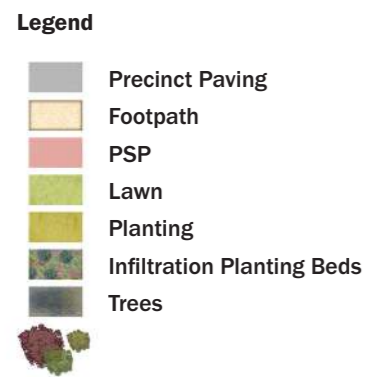

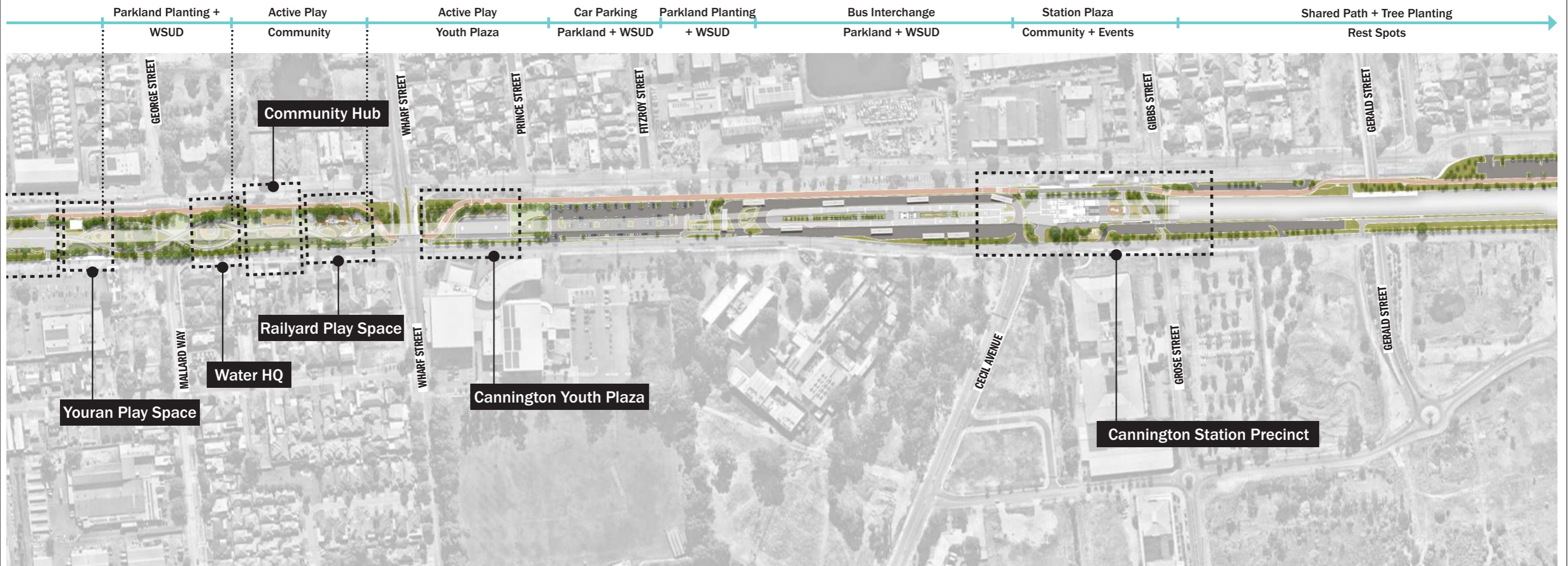

5.3 QUEENS PARK STATION

STATION PLAZA

5.3.1 Queens Park Station

The local Queens Park community members, engaged through METRONET, stated that the Station Precinct should be a place with a strong sense of community belonging, as they are proud of their diversity.

The plaza precinct design includes strong pedestrian connections to local schools, transit, shops and businesses. A wide open plaza provides space for activation and abundant native planting representing the 'Boree Boree' station identity of 'wide open plains'.

The plaza precinct links to active spaces within the corridor to the north and south being play spaces, linear parkland, community event spaces and parking.

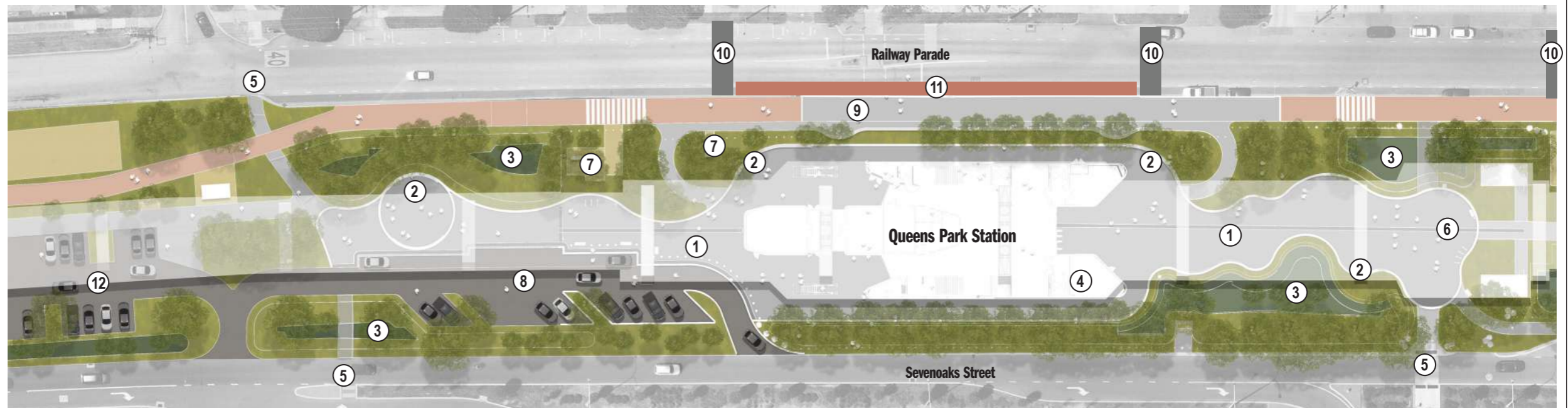

- ① Station forecourt with surrounding seating walls for informal seating, gathering, waiting and resting.
- ② Seating nodes comprising paving highlights, low concrete seating wall with integrated lighting and timber tops create opportunities for gathering, waiting and resting.
- ③ Large shallow drainage basins with wetland planting.

- ④ Bike storage within station building.
- ⑤ Path and cross corridor connections to surrounding pedestrian network.
- ⑥ Station Plaza that links to the adjacent play space and community hub lawns creating a large activation space for community events such as markets, food trucks and music events.
- ⑦ Transformer with buffer screening planting.

- ⑧ Station car park accommodating all special bays such as electrical car charging, accessible, short term, kiss and ride and taxi bays.
- ⑨ Principal Shared Path (PSP) retained as existing with upgrades to accommodate crossing points and interface with intersection. Applied treatments for slowing cyclists near station plazas as per PSP strategy.

- ⑩ Indicative locations for new Railway Parade raised pedestrian crossings - to be coordinated with LGA and civil teams.
- ⑪ Kiss'n'Ride Bays to Railway Parade to be marked as 15min bays - to be coordinated with LGA and civil teams.
- ⑫ Park'n'Ride car park for long term bays.



Station Precincts

The Station Precincts contain the following amenities:

Legend

- Precinct Paving
- Footpath
- PSP
- Lawn
- Planting
- Infiltration Planting Beds
- Trees

5.3 QUEENS PARK STATION

STATION PLAZA



5.4 CANNINGTON STATION

STATION PLAZA

8.5.1 Cannington Station

'Cannington is deeply embedded in its local riverine ecology, it is surrounded by wetlands, rivers and streams. Enhanced ecological connections run from the Canning River to Queens Park Regional Open Space, through a series of local parks, green streets, drainage basins and channels.'

Living and thriving in this beautiful landscape is the Red Tailed Black Cockatoo. Numerous layers of interpretation layer over this station and precinct's design to celebrate the station identity as provided by the MNRG - Karakaliny - Place where the red tail cockatoo moves.

The Plaza precinct celebrates the water landscape through numerous drainage basins and wetland planting.

The prominent location of the station building and large civic plaza forecourt provides a significant landmark for the community at the end of Cecil Avenue - a key urban corridor for the City of Canning.

Space is provided for activation, hospitality, social gathering and recreation in the large plaza, forecourt, bouldering space and circular board walk over drainage basin.

Strong pedestrian and cycle connections are provided between various adjacent neighbourhood streets, schools, businesses and future planned connections.

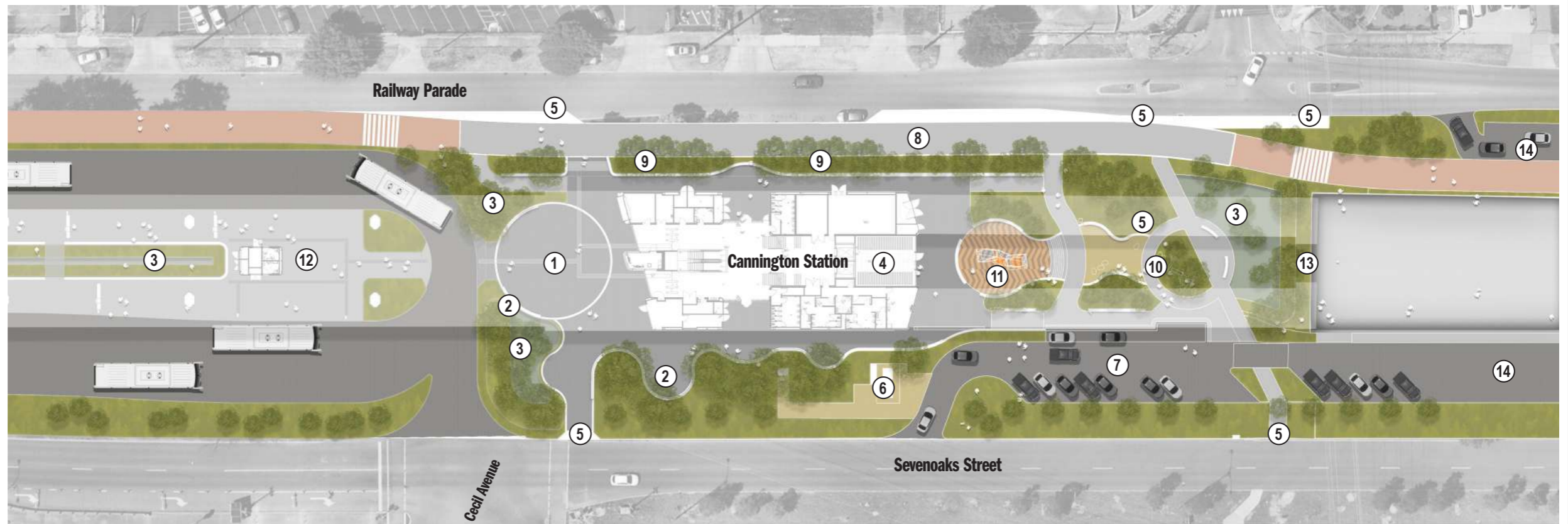

- ① Station forecourt with surrounding seating walls for informal seating, gathering, waiting and resting
- ② Seating nodes comprising paving highlights, low concrete seating wall with integrated lighting and timber tops create opportunities for gathering, waiting and resting
- ③ Large shallow drainage basins with wetland planting
- ④ Bike storage within station building
- ⑤ Path and cross corridor connections to surrounding pedestrian network
- ⑥ Transformers with buffer screening planting

- ⑦ Station car park accommodating all special bays such as electrical car charging, accessible, short term, kiss and ride and taxi bays.
- ⑧ Principal Shared Path (PSP) with surface changes to highlight pedestrian conflict points and access to station
- ⑨ Planting buffer between corridor pedestrian areas and PSP to create safer pedestrian and cyclist environment.
- ⑩ WSUD basin with stepping stones trails
- ⑪ Active recreation space includes bouldering wall and surrounding seating

- ⑫ Bus Interchange
- ⑬ Abutment wall
- ⑭ Long stay (Park'n'Ride) parking

Station Precincts

The Station Precincts contain the following amenities:

Legend

- Precinct Paving
- Footpath
- PSP
- Lawn
- Planting
- Infiltration Planting Beds
- Trees



5.4 CANNINGTON STATION

STATION PLAZA



06 STATIONS

6.1 STATION DESIGN INTRODUCTION

Station design has played a historic role in the development of communities along the Armadale Line since its creation in 1889. As the elevated station buildings become more prominent, it is important to ensure that they become significant urban markers without forming new physical and visual barriers.

Established in the 19th Century

Station design has played a historic role in the development of communities along the Armadale line since its creation 1889.

Original stations

- Perth
- Welshpool
- Kelmscott
- Armadale
- Cannington

The arrival of the stations catalysed suburban growth forming the focal point of the emerging communities. As the relative importance of the road network has grown over the course of the 20th century, the significance of suburban stations at the heart of communities has diminished.

The LXR Program represents the single biggest line-wide investment in a generation. The elevation of the railway and removal of physical barriers between the Eastern and Western halves of the suburbs has the potential to once again transform their communities.

Future Forward Opportunities

In its current configuration, the ground level experience of the train line is of a fence, and in several locations, overhead power cables. By elevating the rail, these physical barriers will be replaced by a generous urban park and amenities. As the barriers are removed and the space between the line becomes a vibrant community asset, the stations once again have the potential to become an important amenity in support of their precincts and established neighbourhood centres. Safe and vibrant community places around which further transit oriented development can take place.

As the station buildings become more prominent, it is important to ensure that they become significant urban markers without forming a new physical and visual barrier. In developing the station design, the ALUA team has taken care to break up the station massing in order to maximise visual porosity whilst providing sufficient amenity and weather protection. By taking into account these competing urban drivers the design aims to strike the balance between creating a strong community focal point within a minimal physical footprint.

A 21st Century Australian Vernacular Station

The opportunity of opening up the line combined with the increased physical presence of an elevated station building offers the opportunity for the station architecture to once again become a physical focal point and architectural expression of community.

The Inner Armadale Line travels through a number of connected yet diverse communities with a specific distinction drawn between the innermost stations at Carlisle and Oats Street and the outer stations where the urban grain opens up to a more diverse urban context and eventually, to the hills.

The primary character of all the station precincts is residential; in developing our standardised station design we have drawn upon the local residential vernacular in creating a rooted yet porous plinth and sloped upper facade that references the distinctive suburban roofscape. In order to maximise visual porosity and the removal of physical barriers, the upper canopy has been physically detached from the station building plinth as far as possible, lending a dynamism to the station by expressing its function as a train station in harmony with, yet distinct from, the adjacent residential vernacular.



6.2 STATE PLANNING POLICY 7.0

State Planning Policy

State Planning Policy 7.0 Design of the Built Environment (SPP 7.0) forms part of the State Government's Design WA initiative which seeks to ensure that all developments across the state promote good design. SPP 7.0 identifies ten overarching design principles which are required to achieve good design.

ALUA has reviewed the state planning policy and incorporated these 'good design' principles throughout the IALXR Project. The following outlines a general approach to the application of these 'good design' principles.

Refer Section 8.0 for station design solution.



1. Context and Character

Good design responds to and enhances the distinctive characteristics of a local area, contributing to a sense of place.

The Inner Armadale Stations will be carefully embedded into each precinct. They will be 'good neighbours' by enhancing and celebrating the elements that make each place unique, building on local Aboriginal and post-colonial (hi)stories. The stations will recognise the buildings, streets and landscapes appreciated by the locals from the vernacular Australian homes to the watering holes and wetlands by the Swan River.

The stations materiality and colouration will be designed to be distinct and responsive to local contexts whilst maintaining a consistent line-wide character.

Refer to Section 8.0 for specific details on the Context and Character response.



2. Landscape Quality

Good design recognises that together landscape and buildings operate as an integrated and sustainable system, within a broader ecological context.

The hard and soft landscape, and urban design elements throughout the corridor will be imbued with stories and meaningful connection to the community, to First Nations 'Country', to place, and beyond. The elements will be applied to create external environments that interact in a considered manner with built form, resulting in well-integrated, engaging place that respond to the local identity and streetscape character.

The consideration of environmental factors such as water and soil management, ground and site conditions, solar access, micro-climate tree canopy, urban heat island impacts, habitat creation and preservation of green infrastructure will also be incorporated in the landscape design. A native planting palette will be introduced to define character and promote biodiversity and restore lost or damaged ecosystems and endemic vegetation complexes, where possible.



3. Built form and Scale

Good design ensures that the massing and height of development is appropriate to its setting and successfully negotiates between existing built form and the intended future character of the local area.

The scale, massing and height of the station building will respond to adjacent planned built fabric and blend with the residential developments, whilst acknowledging the natural landform characteristics of the broader region.

The orientation, proportion, composition, and articulation of built form elements will be suited to the purpose of a transit-oriented development. Through defining the public domain of a station precinct, contributing to the character of adjacent streetscape and open spaces, and providing good amenity for people at ground level with connections to important views, vistas, and landmarks.

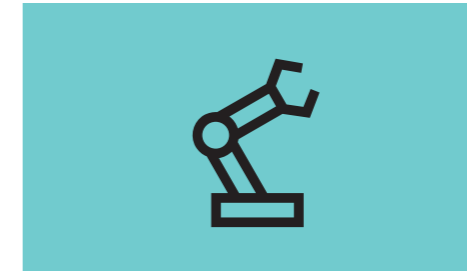

4. Functionality and Build Quality

Good design meets the needs of users efficiently and effectively, balancing functional requirements to perform well and deliver optimum benefit over the full life-cycle.

The stations will be functionally simple and efficient. The clear arrangement of un-paid and service spaces will facilitate good relationships between spaces and ease of use. The design will be flexible and adaptable for future requirements without the need for major modifications.

The new rail infrastructure will become a long-term asset for each neighbourhood that get 'better with age'. Good build quality will be achieved by using durable materials, finishes, elements and systems that are easy to maintain and weather well over time. Architectural product selections and details will focus on resilience to wear and tear expected from intended use, upgrade ease and maintenance minimisation.

An integrated systems approach will be implemented to achieve a functional and serviceable final outcome, without detriment to aesthetic appearance. Consideration will be given to the full life-cycle of systems and mitigation of potential climate change impact

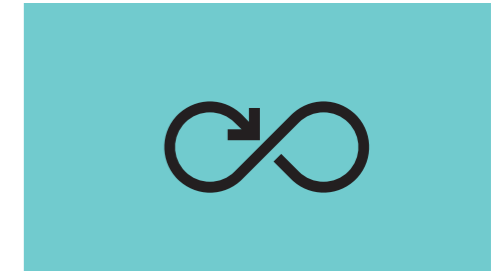

5. Sustainability

Good design optimises the sustainability of the built environment, delivering positive environmental, social and economic outcomes.

The stations and connections across the line will offer quality low-emission transport options for thousands of locals, based around modern station environments and paths across the rail line.

The proposal will apply a sustainability approach through the use of passive environmental design measures, response to local climate and site conditions, provision of orientation, shading, thermal performance and natural ventilation. Water-sensitive urban design and landscape principles will be applied to minimise negative impacts on existing natural features and ecological processes.

The reduction of reliance on technology for heating and cooling will minimise energy use, resource consumption and operating costs over the life-cycle of the project. The use of sustainable construction materials, recycling, good waste management practices, re-use of materials and existing structures, harnessing of renewable energy sources, and total water cycle management will also be incorporated, where applicable.

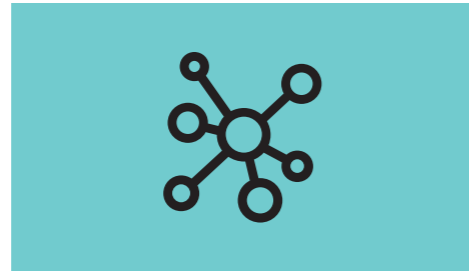

6. Amenity

Good design provides successful places that offer a variety of uses and activities while optimising internal and external amenity for occupants, visitors and neighbours, providing environments that are comfortable, productive and healthy.

The corridor's landscape and activity spaces will offer universally accessible places and opportunities for people to meet and socialise, providing optimal levels of external amenity, functionality and weather protection while encouraging social inclusion, equitable access and respect for the public and neighbours

Paid zones, service rooms and other internal spaces will be adequately sized, comfortable and easy to use and furnish, with good levels of daylight, natural ventilation and outlook. Where applicable, appropriate levels of acoustic protection and visual privacy, adequate storage space, and ease of access for all will be provided. Considerations have also been made about appropriate densities that are consistent with projected population growth, and able to be sustained by existing or proposed transport, green and social infrastructure.

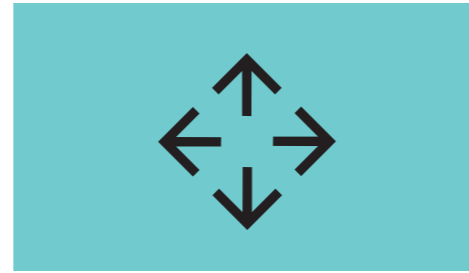

7. Legibility

Good design results in buildings and places that are legible, with clear connections and easily identifiable elements to help people find their way around.

Sight lines will be well-considered throughout the station site, with built form responding to important vantage points, taking key consideration of surrounding neighbourhoods, major intersections and significant buildings. Access and circulation within and around the perimeter of the station will contribute to a fine-grain network of direct and connected routes within and beyond the station site. The purpose of this approach is to prevent the station from becoming a large non-permeable block.

At ground level, the station building will be easily recognisable as a public transit facility and the station entries will be clearly identifiable and orientated to serve efficient and intuitive wayfinding. Pedestrian movement is given priority over vehicular movement.

This architectural legibility will support connections to existing movement networks by enhancing ease of navigation through the station and its surroundings.



8. Safety

Good design optimises safety and security, minimising the risk of personal harm and supporting safe behaviour and use.

New spaces beside and under the rail will feel a part of the neighbourhood. Appropriate measures will be integrated to ensure paths and activity spaces along the corridor are well-lit and maximise passive surveillance to ensure a comfortable journey. The design of vehicular transport routes such as busways and vehicle drop-offs will be configured to mitigate negative impacts on pedestrian amenity.

Within the station building, opportunities for passive surveillance will be maximised through the provision of clearly defined paid and un-paid spaces with well-lit secure access points.

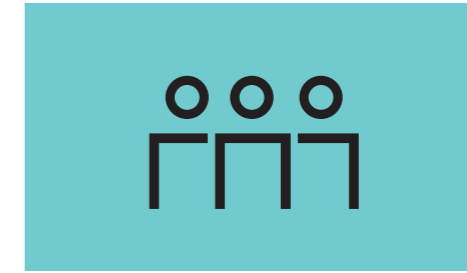

9. Community

Good design responds to local community needs as well as the wider social context, providing environments that support a diverse range of people and facilitate social interaction.

The station design will respond to existing and planned future retail, commercial and residential development, with a focus to encourage social engagement and physical activity in an inclusive, equitable manner and consider how the new station facility can contribute to activation of adjacent public spaces.

In addition, the significant public realm investment is focussed on the community use and benefit. Careful consideration has been given to high level of integration with local movement networks to improve general access from these highly walkable neighbourhoods.



10. Aesthetics

Good design is the product of a skilled, judicious design process that results in attractive and inviting buildings and places that engage the senses.

The new rail infrastructure will be part of each neighbourhood long into the future. The look and feel of stations and the places around them should be simple with an emphasis on functionality. The identity of each station precinct will be reflected in each neighbourhood, with unifying features that demonstrate continuity along the lane.

The station design will address all scales, from the articulation of building form through to the selection and detailing of materials and building elements.

Aesthetics will not be limited to style and appearance; the coherence of the design concept and the cultural relevance of the station will also be taken into account. Good waste management practices, re-use of materials and existing structures, harnessing of renewable energy sources, and total water cycle management will also be incorporated, where applicable.

6.3 NOONGAR PLACE NAMES

Carlisle DJOO-RAL-UP

As referenced on the Department of Local Government, Sport, and Cultural Industries Gnarla Boodja Mili Mili project, Joorolup is the traditional name closest to the Carlisle train station. It comes from the Djooroo or jarrah and is the totem of the Djooral Kalla which is the clan group who governed the region. Djooralup the place of the djooral (jarrah).

Djooralup

Place of the Jarrah Tree



Oats St MUNDEE

Upon the arrival of the British in 1829, Mundee the Noongar leader governed the land of Beeloo as the tribal leader of the Djooral Kalla (Djeeral) clan. Mundee's Kalla or clan of 32 persons was identified. The Elders approved the use of Mundee to promote the heritage and history of the region and gives recognition to the Noongar leader of the Beeloo territory.

Mun-dee

Noongar leader of the Beeloo territory



Queens Park BOREE BOREE

Booree Booree is the flat plain surrounding Queens Park region and it is referenced by Bates 1992 as being the land governed by Joobaitch a prominent Noongar leader. Flat plains were often used to drive animals into the open to hunt which made it easier to catch them. Bor-ee Bor-ee, the great mass of land or large flat plain.

Bor-ee Bor-ee

Great mass of land or large flat plain



Cannington KARAKALINY

Cannington has been well known by many Noongar people as the Karakaliny (Karragullen) due to the number of red tail cockatoo that frequent the area. The verification of the name of Karakaliny was provided through consultations with Elders who had the knowledge passed down from generation to generation. Karak is the name of the red tail cockatoo and due to the number of red tail cockatoo in the area the local Noongar call this place Karakaliny, the place of the red cockatoo.

Karak-al-iny

Place where the red tail cockatoo moves



Beckenham DJARLGARRA

Djarlgarra is the traditional name of the Canning River, a significant place due to its association with the Waagul or rainbow serpent. Interviews with Elders validated the need to protect and promote the traditional names and dreaming of the water ways. Beckenham station is the closest station to the Canning River and will promote the traditional name of Djarlgarra to educate the community. Djarlarra the place of abundance.

Djarl-gar-ra

Place of abundance



6.4 COLOUR IDENTITY

IDColour

Metalwork Platform Canopy Soffit

Floor finishes Platform & Concourse

Station Plaza Paving

Brick work

Primary Brick

Accent Brick

Carlisle

Dojoorolup



Jarrah Trees



White



Exposed Aggregate Effect Tile



Black Cement with TBD Aggregate



Grey Cement with TBD Aggregate



Cream Cement with TBD Aggregate



Capital Red



Embassy Red

Oats Street

Mundee



Mundee / Echidna



White



Exposed Aggregate Effect Tile

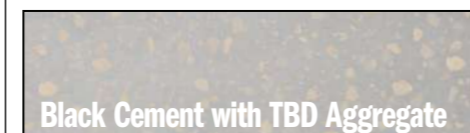

Black Cement with TBD Aggregate



Grey Cement with TBD Aggregate



Cream Cement with TBD Aggregate

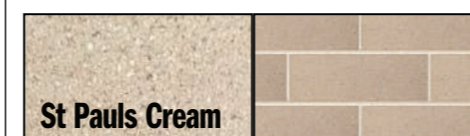

St Pauls Cream



Simmetal Silver

Queens Park

Boree Boree



Banksia - Coming Together

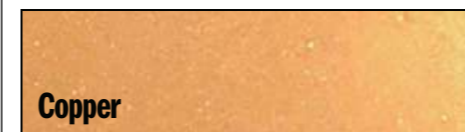

Copper



Exposed Aggregate Effect Tile



Black Cement with TBD Aggregate



Grey Cement with TBD Aggregate



Cream Cement with TBD Aggregate

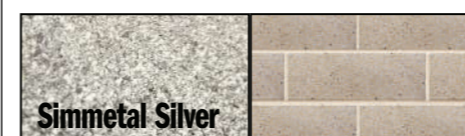

Simmetal Silver

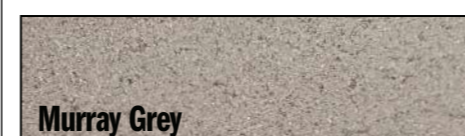

Murray Grey

Cannington

Karakaliny



Red Tailed Black Cockatoo



Copper Bronze



Exposed Aggregate Effect Tile



Black Cement with TBD Aggregate



Grey Cement with TBD Aggregate



Cream Cement with TBD Aggregate



Murray Grey



Brahman Granite

Beckenham

Djarlgarra



Melaleuca / Paperbark



Champagne



Exposed Aggregate Effect Tile

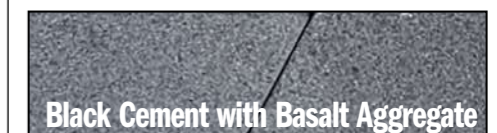

Black Cement with Basalt Aggregate



Grey Cement with Basalt Aggregate



Cream Cement with Basalt Aggregate

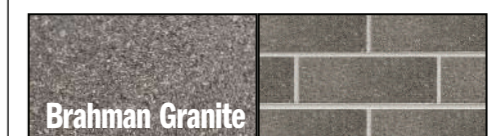

Brahman Granite



Borwal Blue

6.5 BRICKWORK

Preliminary Selections

Austral Bricks Borwal Range

*Final Color Selection Subject To Samples/Mock Up's

Radial & Transition Bricks

Radial bricks are used to achieve curved brickwork. Bowral Bricks offers a wide range of radii to provide greater potential for rounded forms. Transition bricks are provided to avoid poor quality junctions where curved brickwork meets straight walls. All radial shapes are available as standard 76mm height (pictured) or as a 50mm slimline version.

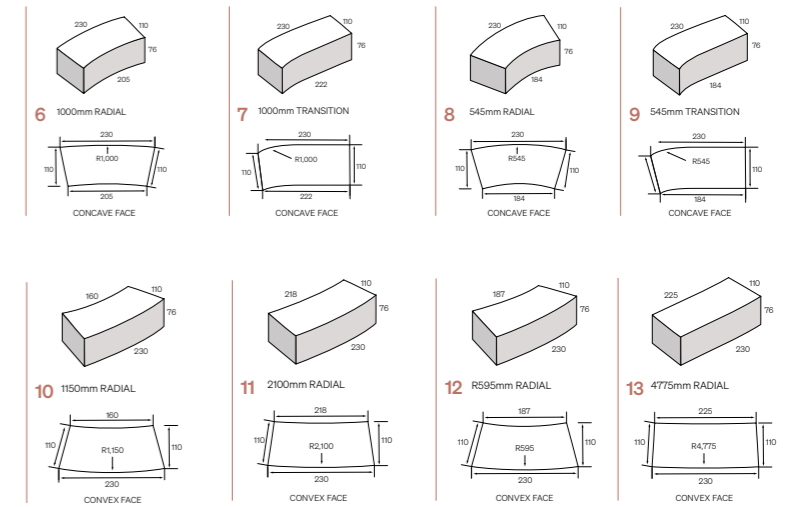
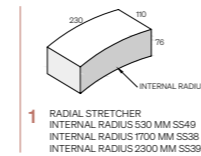

<p>Primary Brick</p>	<p>Primary Brick</p>	<p>Primary Brick</p>	<p>Primary Brick</p>	<p>Primary Brick</p>
<p>Carlisle Capital Red</p> <p>Accent Brick Embassy Red</p>	<p>Oats St St Pauls Cream</p> <p>Accent Brick Simmetal Silver</p>	<p>Queens Park Simmetal Silver</p> <p>Accent Brick Murray Grey</p>	<p>Cannington Murray Grey</p> <p>Accent Brick Brahman Granite</p>	<p>Beckenham Brahman Granite</p> <p>Accent Brick Borwal Blue</p>

6.6 PLATFORM & CONCOURSE TILES

Exposed Aggregate Effect Tile
Unique Colour Combination For Each Station



Carlisle

Red

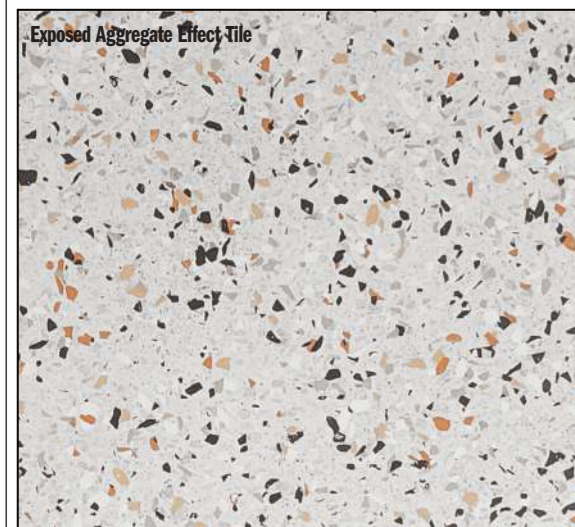

Oats St

Cream

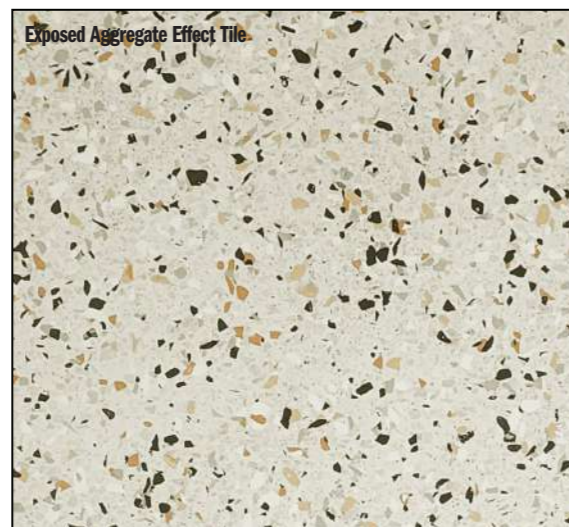

Queens Park

Copper

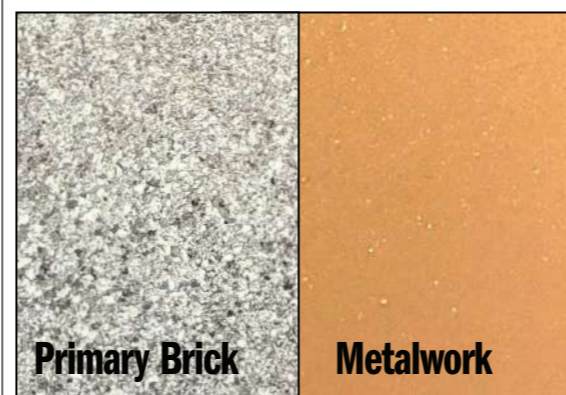
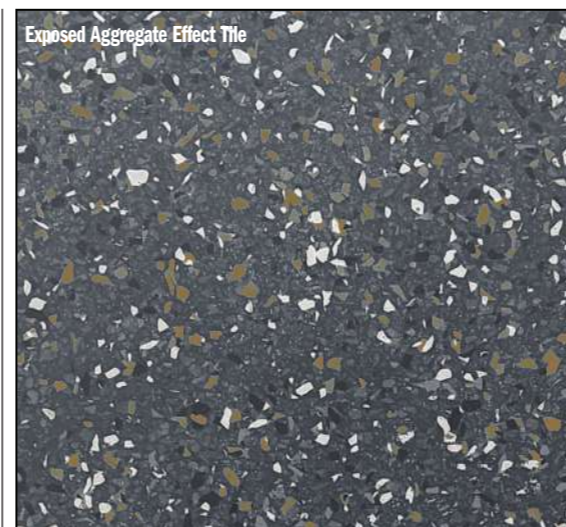

Cannington

Copper / Bronze



Beckenham

Champagne

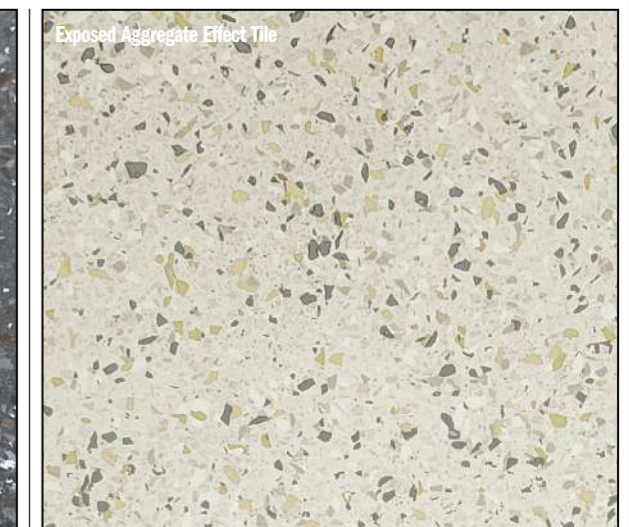

6.7 QUEENS PARK STATION

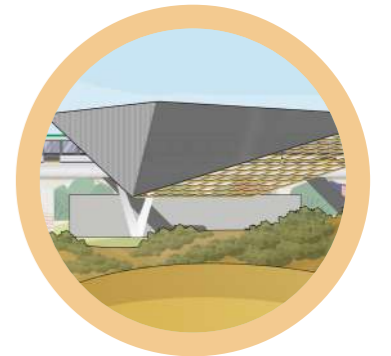

Queens Park
Urban Grain Opening Up To
Perth Hills

'The local Queens Park community members engaged through METRONET told us that the station precinct should be a place with a strong sense of community belonging, as they are proud of their diversity. They would also like the station precinct to express links to important natural places, bringing greenery in. Whilst the significance of Sister Kate's is acknowledged, and its stories should be told through education..'

LXR-MNO-MET-PN-STR-0003 - QUEENS PARK STATION PRECINCT PRELIMINARY PLACE PLAN

Queens Park Station Sense of Place

The Preliminary Place Plans, urban analysis and community engagement programs all identify a distinct change in the character and composition of the suburbs South of Welshpool where the urban grain opens up significantly and plot sizes enlarge. As the inner suburbs developed in the early part of the 20th century, the outer Armadale Line suburbs were subdivided into a wider variety of smallholdings and market gardens with urban planning partially dictated by the existing ground and subterranean water networks connecting to the Canning river system. The natural environment and water stories also form the strongest component of Queens Park's Aboriginal Heritage Narrative.

The Preliminary Place Plans identified the following key 'Sense of Place' components

- Consolidate community values, history and future aspirations.
- Help define an authentic place character that reflects the context and needs of the local community.
- Define a distinct experience that differs from other station precincts, giving people a reason to visit, live and invest in the precinct, stimulating the urban economy and developing a deeper community life.

members engaged through METRONET stated that the Station Precinct should be a place with a strong sense of community belonging, as they are proud of their diversity. They would also like the station precinct to express links to important natural places, bringing greenery in. Whilst the significance of Sister Kate's is acknowledged, and its stories should be told through education.

Adapting the Standardised Station Design

The theme of nature and water were strong strands running through the community engagement sessions and ALUA's artists workshops. These themes have been used to adapt the standard design, which still strongly relates to the primarily residential suburbs:

- A rich reflective coppery earth tone material has been applied to the soffit and lattice of the station in reference to the richness of the earth and natural water holes.
- The distinctive earthy colour of the station will form a distinctive landmark, which is more visible from a greater distance given the larger urban grain and distance of adjacent properties. The roof line has a commonality with the adjacent St Joseph's school and the wider residential suburb.

- The larger urban grain of the outer suburbs means that the shade and structure provided in the under rail parkland will provide much need shade in the summer months.

The relative openness and bright colour of the station design response aims to provide a contextual landmark for Queens Park. The landscape and integration of artwork will have an important role to play in offering opportunities to represent the diversity of the community.



Station Elevation



Current Site



Elevation



Platform

The local Queens Park community



QUEENS PARK

Concourse Level

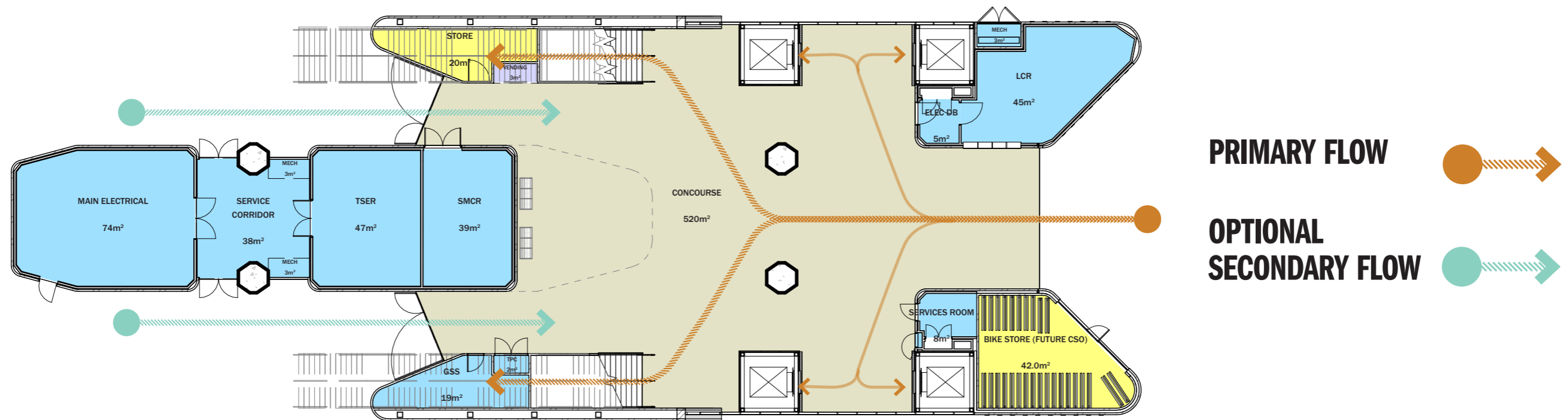

Concourse level - Day One

Materiality

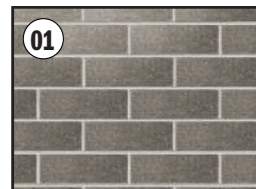

01
Facing Brickwork
Black Face Brick

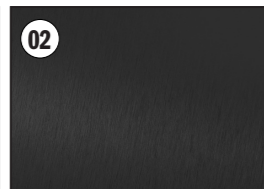

02
Painted Steel Structure
N65 Graphite Grey

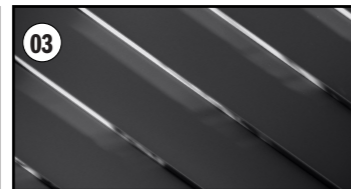

03
Standing Seam Cladding
Monument

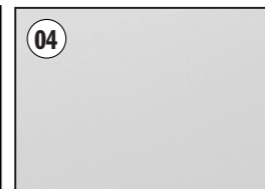

04
Aluminium Ceiling Panel
Powdercoat - White TBC



05
Station Viaduct Piers
Concrete

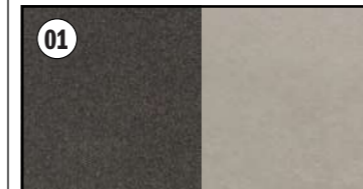

01
Slip Resistant Ceramic Tiles
R12 Microgrip - Choc or Ash Grey



02
Coated Steel Roof Fascia
Colorbond Ultra - Match Roofing Selection



03
Aluminium Ceiling Panel
Anodised Copper

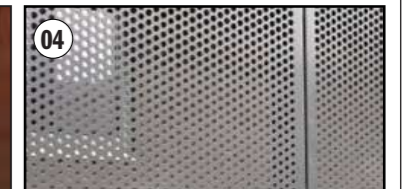

04
Perforated Screen Panels
Aluminium - Colour TBC



Platform



Entry Zone



Perspective

6.8 CANNINGTON STATION



Cannington
Urban Grain Opening Up To
Canning River

'Cannington is deeply embedded in its local riverine ecology, it is surrounded by wetlands, rivers and streams. Enhanced ecological connections run from the Canning River to Queens Park Regional Open Space, through a series of local parks, green streets, drainage basins and channels..'

LXR-MNO-WSP-LA-RPT-0003 - CANNINGTON STATION PRECINCT PRELIMINARY PLACE PLAN LITE

8.5.1 Cannington Station Sense of Place

The strong natural water stories and residential character of the suburb identified at Queens Park station are further reinforced as we move closer to the Canning River. Cannington played an important role in the development of the municipality and the South West rail network. The continuing vibrancy of the suburb is reflected in current passenger numbers the visual prominence of the upgraded station should reflect this significance with an appropriate urban marker.

The Preliminary Place Plans identified the following 'Sense of Place' components:

- Consolidate community values, history and future aspirations.
- Help define an authentic place character that reflects the context and needs of the local community.
- Define a distinct experience that differs from other station precincts, giving people a reason to visit, live and invest in the precinct, stimulating the urban economy and developing a deeper community life.

8.5.2 Adapting the Standardised Station Design

The constraints of rail geometry mean that Cannington will be the only island platform station in this upgrade package. The challenges and opportunities in adapting the standard station design to an island template combined with the strong local water and nature stories have lead to the adoption of the following design drivers:

- The nature of the island platform and relative proximity of neighbouring properties offer the opportunity to diffuse the platform facade with a less solid treatment. An angled lattice facade has been developed that retains a common language with the neighbouring stations - though with much higher levels of transparency.
- The proposed station lattice skin will form a community landmark with potential for the integration of artwork that will be particularly distinctive when combined with the lighting strategy. The station is aligned to create a landmark beacon along Cecil Avenue.
- The adoption of a copper and black materiality speaks directly to the black cockatoo and nature (hi)stories creating a distinctive landmark.

The current station design uses an preliminary artwork developed with Barry Maguire during AD phase. The prominence of the lattice skin offers the opportunity to further individualise the station in both East and West aspects.

The relatively bright station colour and integrated artwork is intended to communicate a distinctive Cannington narrative with a new community landmark.



Station Elevation



Current Site



Site Aerial

CANNINGTON

Concourse Level

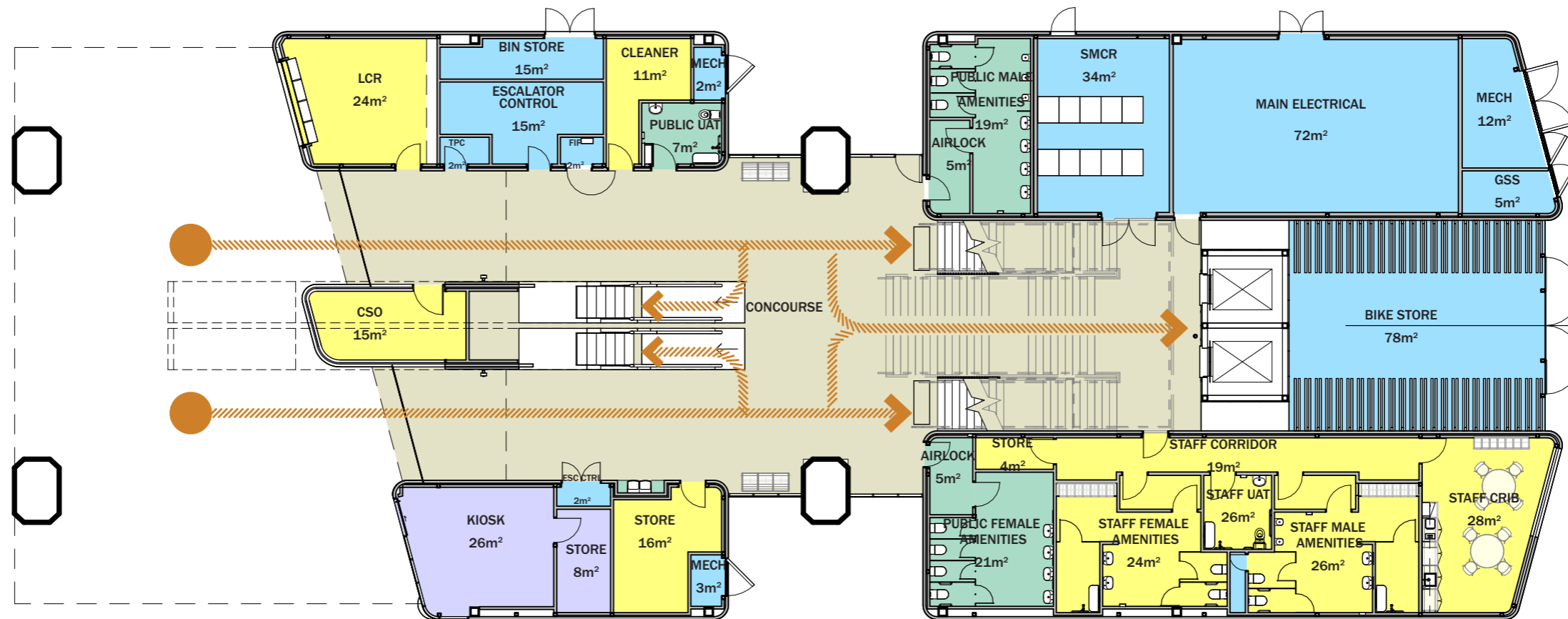

Concourse level

PRIMARY FLOW

CANNINGTON

Material Palette

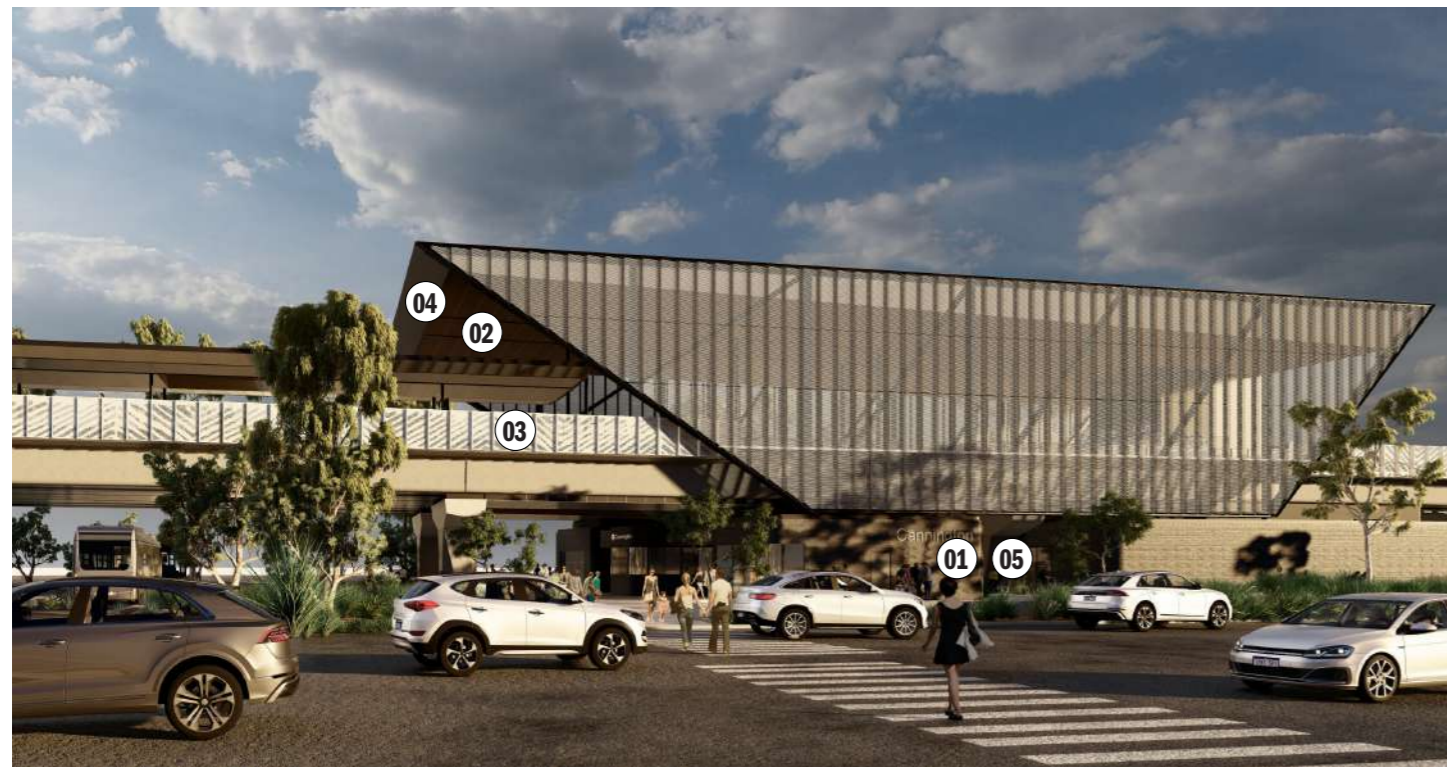

01 Facing Brickwork
Bowral Blue Face Brick

02 Aluminium Ceiling Panel
Powdercoat - White TBC

03 Natural Anodised Perforated Mesh
With Graphic Artwork

04 Coated Steel Roof Fascia
Colorbond Ultra - Match Roofing Selection

05 Station Viaduct Piers
Concrete



01 Slip Resistant Ceramic Tiles
R12 Microgrip - Choc or Ash Grey

02 Aluminium Cladding Panel
Powdercoat - Colour TBC

03 Aluminium Ceiling Panel
Powdercoat - White TBC

CANNINGTON STATION



Entrance Plaza



Platform



View From Cecil Avenue

CANNINGTON INTERIOR



Stairs



Platform



Escalator

07 ACTIVATION

7.1 ACTIVATION

Activation Nodes

The activities, location, scale and orientation of the activities within the linear park have progressed through a detailed design and evaluation process. Each stage informing the next. The existing land uses and interfaces have been key considerations.

Preliminary Place Plans



Derived from engagement with the local community place initiatives were identified

Concept Design

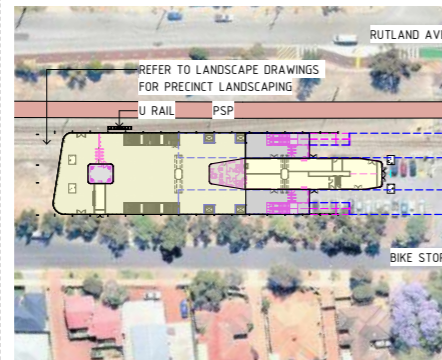

High level concept designs were informed by the Preliminary Place Plans

Reference Design - 15% & Engagement



ALUA commenced the design process conjunction with more detailed local community engagement.

- MySay Survey
- Community Reference Group
- Pop ups
- Business Community Consultation
- Key Stakeholders

Final Place Plans



The Final Place Plans have been formed through a collaborative design engagement process. The Place Plans highlight a refined sense of place but also identify the practical constraints that need to be considered within the linear park.

Design Refinement

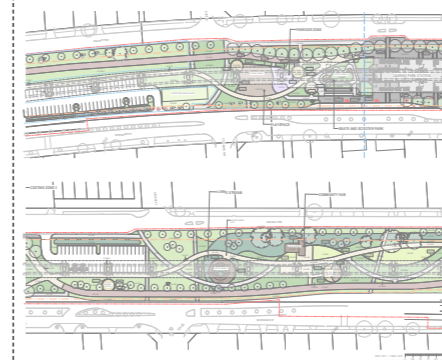

Collaborative sharing of design solutions with key stakeholders. A process of refinement.

Development Application



The design solution considers the strategies and requirements of the place plans and SWTCs and is packaged within this development application.

7.2 ACTIVATION STRATEGY

Activation

The activation opportunities throughout the corridor have been driven by the outcomes of ongoing community engagement and the key aspirations from the Preliminary and Final Place Plans.

This is a park for everyone and therefore flexible and varied ranges of activation opportunities have been included within the design ranging from playgrounds, youth plazas and community spaces.

Activation nodes have been concentrated around the station precincts and activated edges of the corridor with a focus on quieter and more passive activities within the parkland zones where adjacent to residential areas.

Programming of these spaces has been accommodated via supporting amenities such as car parks, power, water (services) charging points and station toilets.

Note: Corridor toilets adjacent to playgrounds and key activation nodes are a possible future provision to be explored with the City of Canning.



LEGEND

- Community Backyard
- Youth Plaza - 12 and Older
- Playground - Primary Age
- All Abilities and Seniors Activity
- Small Seating Node
- Small Exercise Node
- Small Play Node



7.3 ACTIVATION NODES

WHARF STREET PACKAGE



7.4 PLAY STRATEGY

Play Principles

Play is an essential part of childhood development contributing to the cognitive, physical, social and emotional well-being of children and young adults.

Care and consideration will be taken through the ongoing design process to ensure that these development needs are met within an inclusive framework that considers access for all abilities.

Particular notice will be taken of Neurodiversity in children and young adult as it is now believed that at least 1 in 10 people are neurodivergent.

The corridor play spaces will not only need to meet the needs of childhood development through play but contribute to the well-being of the community as a whole. Recreational parks are particularly important as they create a community heart where people can gather and connect with each other.

Our design development will consider:

- Sensory focused design: considering the full range of senses incl. proprioception and vestibular to ensure an all inclusive design that enhances sensory and motor development.
- Occupational Therapy: considering the milestone gross motor developments of specific target age groups to best select play and exercise activities.
- Play Auditor and Access Consultant: ensuring a compliant, safe appropriate design with equitable and dignified access for all abilities.

This page highlights the five key play principles that have formed the foundation for the play strategy.

01

Universal Play

Provide play spaces which engage and reflect the spectrum of users across all abilities (physical and neurodiverse), ages, gender and culture that allow universally access through considered design interventions, compassionate material selections and spaces which encourage shared participation by all users

- Interaction by people of all ages and abilities
- Opportunity for mixed ages and abilities to play alongside and with each other, optimising the use of each play element for a broad variety of play needs, ages, physical skill, capacity and body anthropometrics
- Opportunity for sensory experiences targeting users with sensory processing disorders and mental health illnesses.
- Opportunity for active and passive supervision ensuring sightlines from rest areas

02

Free Play

Create opportunities for children to explore the full range of play behaviours across the park whilst ensuring children have the freedom to design and control their own play experiences and interactions.

- Opportunity for risky and challenging play, appropriate to the target age group (size and ability of the child /teen / adult) whilst maintaining a safety mindset
- Opportunity for interactive and parallel play opportunities, that can accommodate for different developmental and play stages
- Opportunity for secluded and quiet play, whilst maintaining sightlines and child safety

03

All Ages Play

Encourage playfulness throughout the park - play is not just for children. Add whimsical and interactive elements that are not limited to playground spaces.

- Anyone who visits this playground, regardless of their age should find activities, equipment and amenities that they enjoy.
- Within the playspaces particular focus should be made for parents, care givers and grandparents to allow them to better interact actively and socially whilst their children are playing.

04

Creative Play

Create memorable spaces that are unique and respond to the design narrative. Include bespoke responses to create identity and respond to place.

05

Immersive Play

Provide play spaces which are immersive in character, content and setting. In combination with a re-wilding and extensive planting strategy, play spaces provide opportunity for immersion in nature.

- Integration of sensory experiences (foliage, light, colour, sound, texture, water, sand, turf etc)

7.5 DIVERGENT PLAY STRATEGY

Play Principles for Neurodivergent Children

Below are a series of design considerations and implementation principles for planning the play spaces as universally accessible by neurodiverse children.

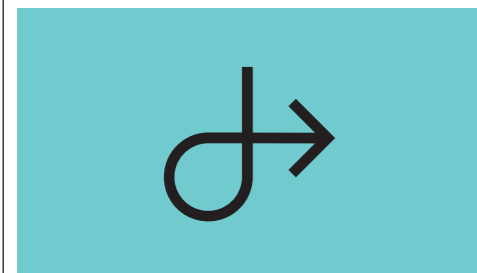

Orientation + Communication

Allow children to assess their play options before engaging. Some neurodivergent children suffer from high levels of anxiety and can be overwhelmed by new environments.

HOW:

- Allow children a sense of control through:
 - Perimeter paths: Provide good perimeter paths so that children can identify play options and determine where they feel comfortable engaging
 - Line of sight: see across the play spaces to allow good orientation



Grouping of Activities

Some neurodivergent children might seek or avoid stimulation. They should be offered a choice – the essence of control. Group the noisy activities together and the quiet activities in another area. Keeping certain activities together helps encourage socialization. Equipment that requires teamwork, like a see-saw, encourages children to communicate with at least one other individual.

HOW:

- Introduce quieter areas throughout play spaces particularly within nature play zones.
- Focus high energy play areas and areas of high intensity together.



Calm Spaces

For children who might get overwhelmed in a busy playground, provide a quiet space away from the noise for a child to regroup or to self regulate.

HOW:

- Provide cubbies and quiet areas within the outer edges and nature play spaces.

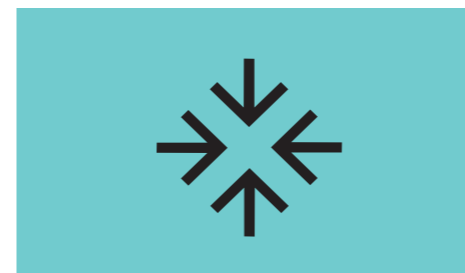

Sensory Activities

Include a variety of sensory experiences including tactile, auditory plus vestibular such as swinging, spinning, balancing etc. and proprioception such as squishing between objects or a touch panel etc.

HOW:

- Provide nature play which will meet many sensory benchmarks
- Add Vestibular elements: crawling/ climbing, see-saws, spinning elements, swings, roller slides
- Add Proprioception elements: totem poles, push panels, fine motor skill play
- Provide balancing logs and steppers within the nature play zone.



Surfaces

Some neurodivergent children can find different surfaces difficult (bark mulch/ sand etc.) and some can have difficulty with balance therefore uneven surfaces are hard.

HOW:

- Offer a range of surfaces including rubber soft fall which is smooth and flat and allows access for wheelchair users to specific play elements.
- Consider that some children mouth elements such as loose surfaces - consider this when placing elements and materials.

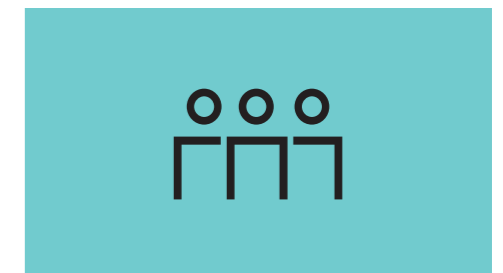

Social Interaction

Neurodivergent children may be anywhere on the Parten's stages of play irrespective of age – some may only wish to be an onlooker, others may wish to play side to side with others. ASD children find the highest level of play (cooperative) challenging.

HOW:

- Ensure there are different types of play available from solitary to parallel and cooperative (such as a see-saw).

7.6 RAILWAY DOG PARK

EXERCISE RUN FOR DOGS OF ALL ENERGY LEVELS

Dog Exercise Area

A dog exercise area has been provided in response to Council and Community comments and in line with City of Canning dog spaces strategy.

The facility comprises two fenced areas totalling 1500m² for high and low energy dogs, both with double airlock gates, agility features, drinking fountains, picnic tables and bench seats the majority of which are under the shade and shelter of the viaduct.

The space is surrounded by a planted buffer visually separating it from the surrounding roads and the PSP through abundant native planting.

Informal street parking and access is provided off Railway Parade.

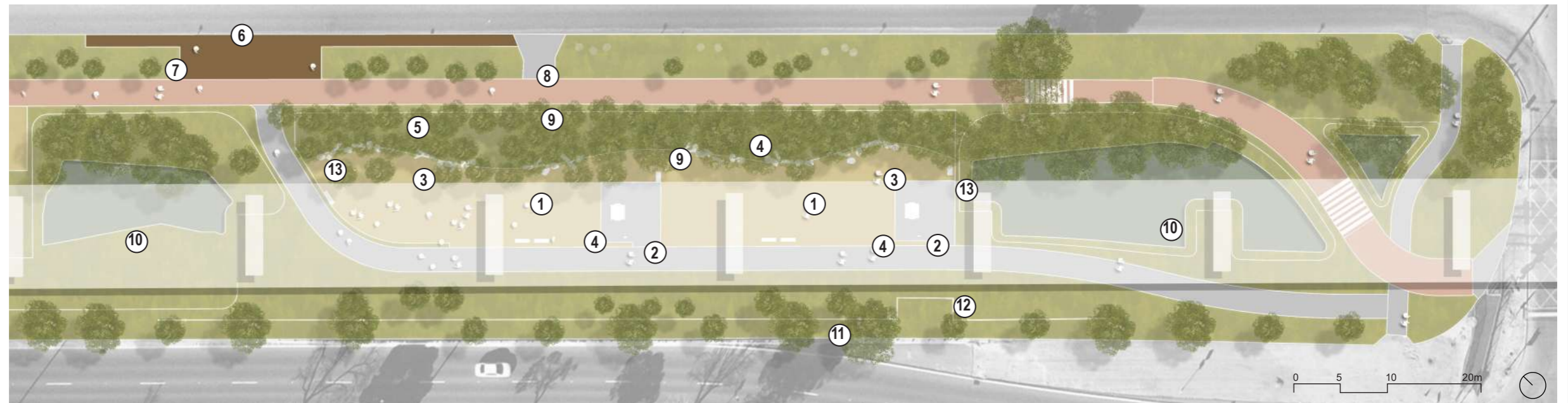

- ① Fenced dog exercise area
- ② Entry points - airlock gates, concrete paving
- ③ Agility features (logs + boulders)
- ④ Bench seating, picnic tables
- ⑤ Planted buffer >3m
- ⑥ Informal street parking
- ⑦ Grass verge / informal access
- ⑧ Existing crossover / maintenance access
- ⑨ Maintenance access gates
- ⑩ Planted shallow drainage basins
- ⑪ Existing retaining wall
- ⑫ Rock pitched slope
- ⑬ Chain link fence (example as pictured)

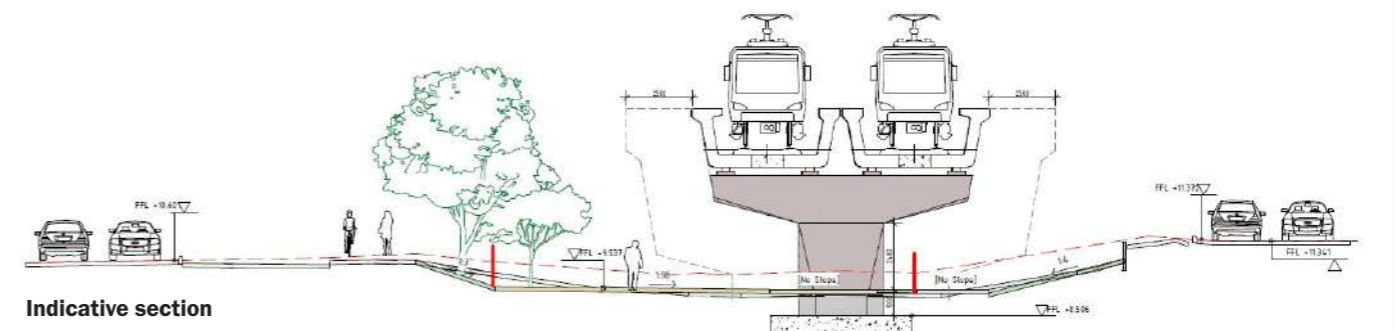

Indicative section
Refer to civil package for grading information



7.7 YOURAN PLAY SPACE

YOURAN - BOBTAIL LIZARD

This small play space has been provided in response to community feedback which requested play opportunities for pre-school children enroute between the school and nearby shops.

Located adjacent the main cross connecting path south of Queens Park Station Plaza, this space marks the transition from urban plaza to parkland.

Small scale sculptural elements provide exploration opportunities for younger children.

The space is located under the viaduct for sun and weather protection and is integrated with surrounding planting and basin areas creating an immersive nature play experience, with boulders, rocks and logs dispersed throughout.

Can you tell the bobtail's head from it's tail?



- ① Bobtail lizard climbing sculptures opportunity
- ② Informal seating through rocks and logs
- ③ Habitat logs, steppers, boulders and recycled materials provide informal play
- ④ Bus stop
- ⑤ Fire Tanks with architectural screening
- ⑥ Emergency stairs
- ⑦ Space nominated for future LGA toilet (still under review)
- ⑧ Large shallow drainage basins with wetland planting
- ⑨ Southern Station Plaza





7.8 WATER HQ

EDUCATIONAL WSUD REFLECTION SPACE

Water Sensitive Urban Design

This space creates a central gathering space within the corridor that highlights and celebrates Water Sensitive Urban Design.

Responding to the local school's request for an outdoor classroom and orientation point, this flexible space can be used by small or large groups.

Seating walls surround a concrete surface with a focal sandblasted map of regional water courses. The space is surrounded by visible water sensitive urban design initiatives such as; large planted drainage basins for water capture and treatment.

Exposed and visible direct outlets from piers and culverts under paths bring visitors attention to the hybrid engineering and ecological drainage system.

The WSUD space is flanked by events/ activity lawns and groves of paper bark trees to provide an immersive natural experience.

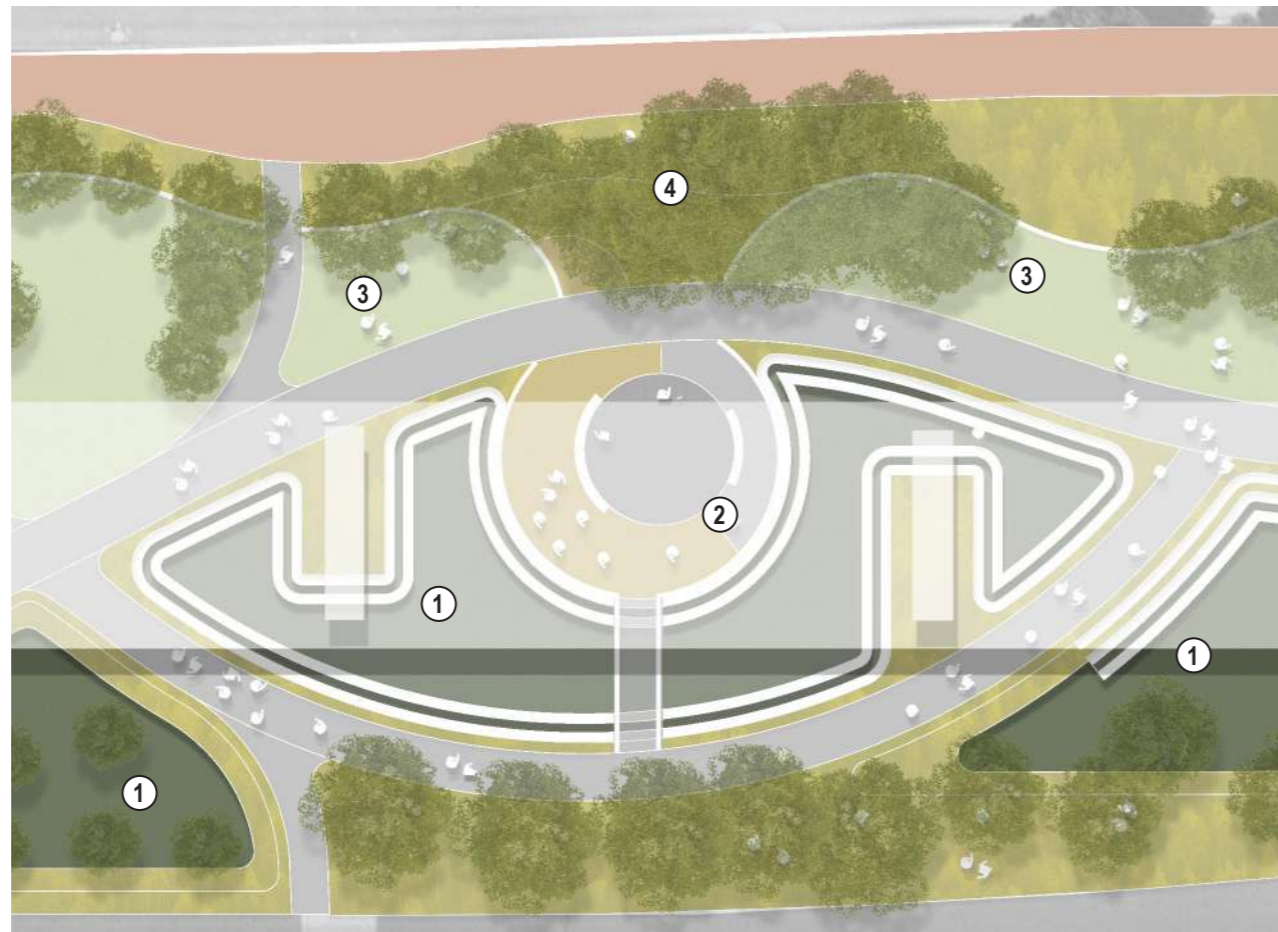

- ① Large, shallow, native planted drainage basins
- ② Seating walls + teaching space
- ③ Events lawns
- ④ Planting palette to relate to water storey





7.9 QUEENS PARK COMMUNITY HUB

ACTIVATION NODE, SHELTERS, BBQS AND EVENTS LAWN

The Queens Park community hub is designed to provide an inviting, flexible events space nestled in the parklands.

Located between Queens Park Station and the adventure Playground, this series of wide open lawns, seating BBQs and picnic tables provides opportunities for everyday use and a wide variety of events.

The central gathering space utilizes the shade of the viaduct, existing trees and custom shade shelters, adding banquet tables, seating walls, benches and bike racks.

While all in close proximity, several clusters of seating allows small or large groups to utilize the space. This was partially in response to community feedback on cultural practices of several local community groups.

Event lawns allow space for food trucks and/or temporary structures or a stage for LGA events.

Equally, small seating nodes and nooks accommodate for individual park users every day uses like lunch, exercise, football or reading.

The whole space is flanked by groves of existing mature trees and new groves of paperbarks within planted drainage basins.

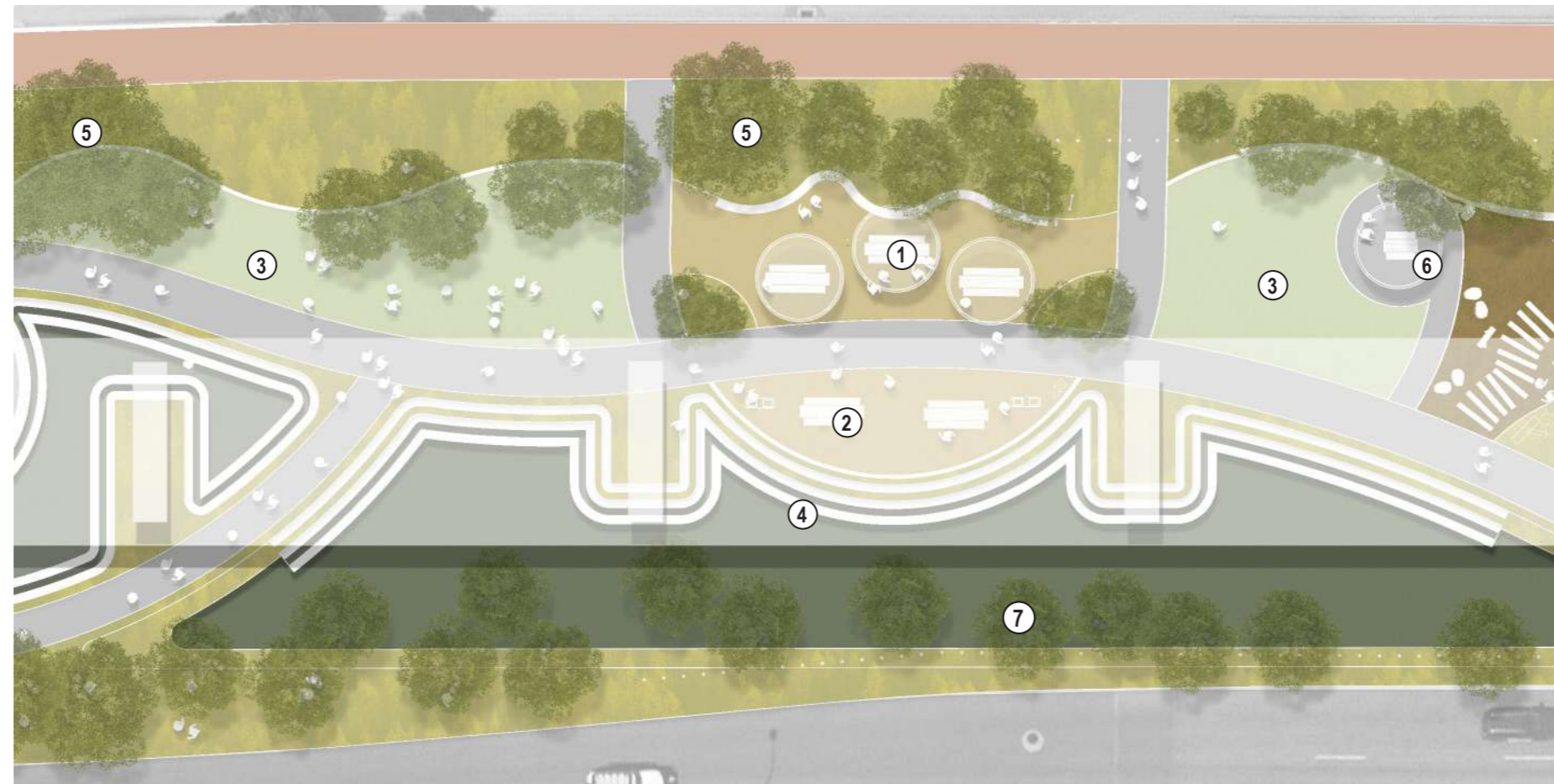

- ① Banquet tables + custom shade shelters
- ② Banquet tables under viaduct
- ③ Events Lawns
- ④ Large shallow planted drainage basins
- ⑤ Existing mature trees
- ⑥ Seating nodes
- ⑦ Melaleuca grove





7.10 RAIL YARD ADVENTURE PLAY SPACE

RE-WILDING THE RAIL YARD

The Queens Park Rail Yard Adventure Play Space draws on the rich history of the Armadale train line - interpreting the old class ADB776 carriages into a modular climbing frame.

Located between the community hub and youth plaza, the playground interprets stories of the train line acting as cultural connector for families and economic enabler, transporting people from Armadale to Perth and everywhere in between.

The design integrates recycled materials such as concrete sleepers, boom gates and signals into climbing and interpretive elements.

A water pump, feeds a series of channels, weirs and discharging into a gravel planted swale, integrating the WSUD features with water play elements.

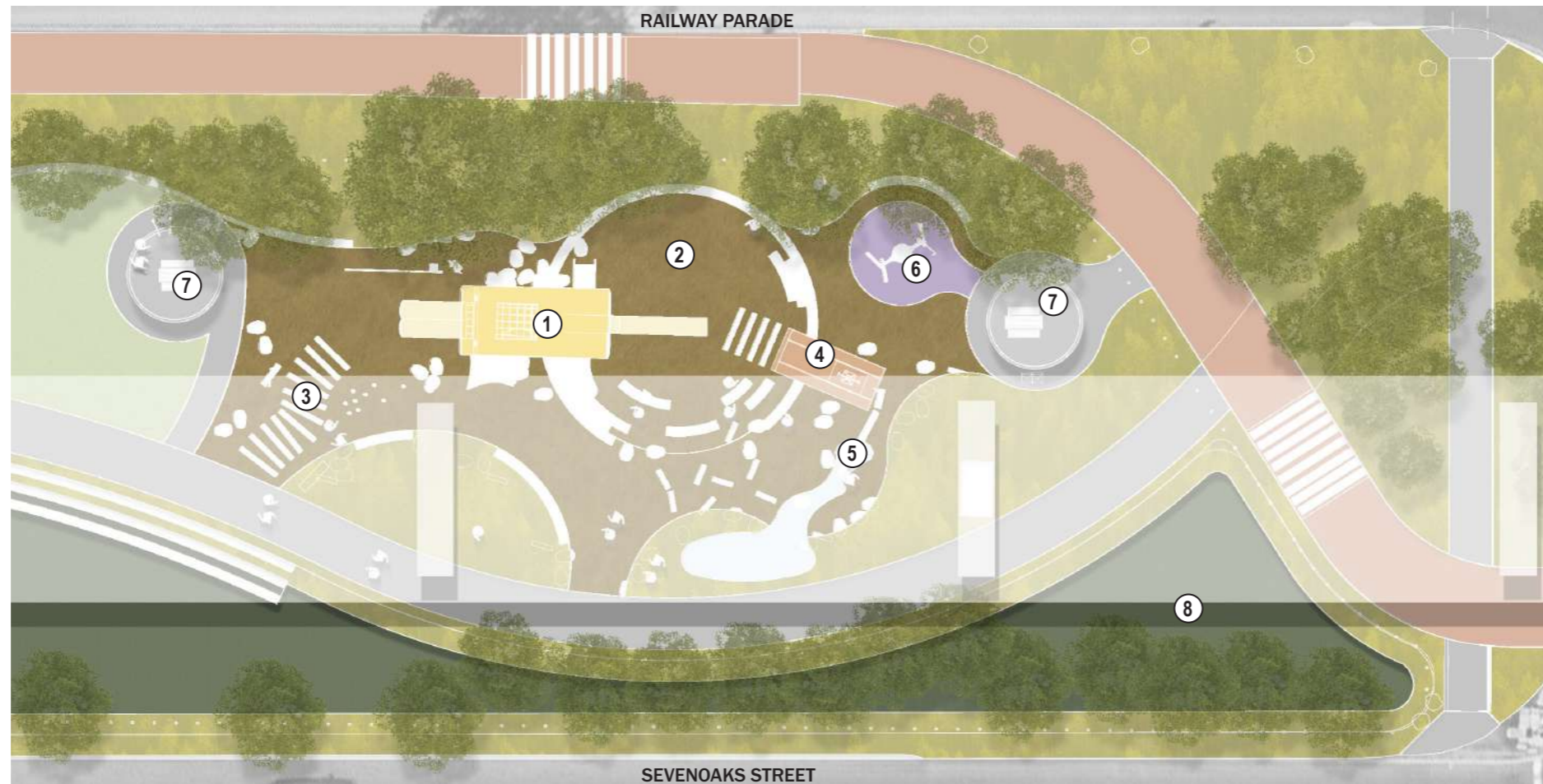

- ① Train carriage custom climbing tower with climbing nets and slides
- ② Railyard turntable interpretive zone
- ③ Recycled rail yard climbing elements - boom gates, sleepers, bush poles
- ④ Boardwalk climbing frame with handcar water pump
- ⑤ Water play zone - pump, channels, weirs, gravel swale
- ⑥ Basket swing
- ⑦ Custom shelters with picnic settings
- ⑧ Planted Drainage Basins



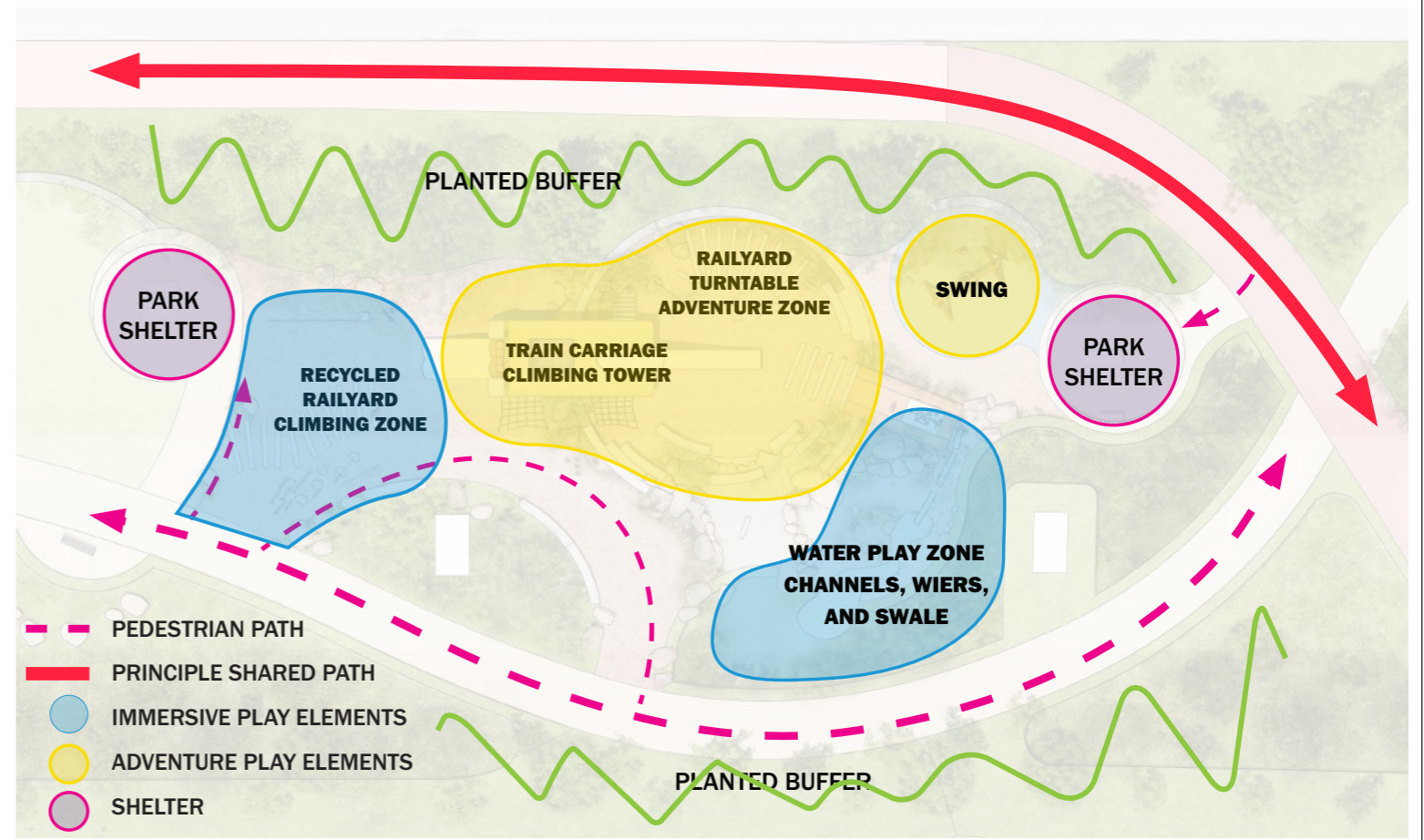

7.11 CANNINGTON YOUTH PLAZA

SKATE PARK + SEATING NODE

Cannington Youth Plaza

A skate plaza has been purposefully located opposite the Cannington Leisureplex to enable shared amenities such as the centres toilets, cafe and car park. This location is also centrally located between the surrounding schools and colleges to support access for users.

A chill out zone has been requested during community consultation will be developed to allow breakout seating to watch the skate zone and hangout with friends.

This space is currently under development with community stakeholder groups and specialist skate park design consultant. Layout shown is indicative and subject to change.

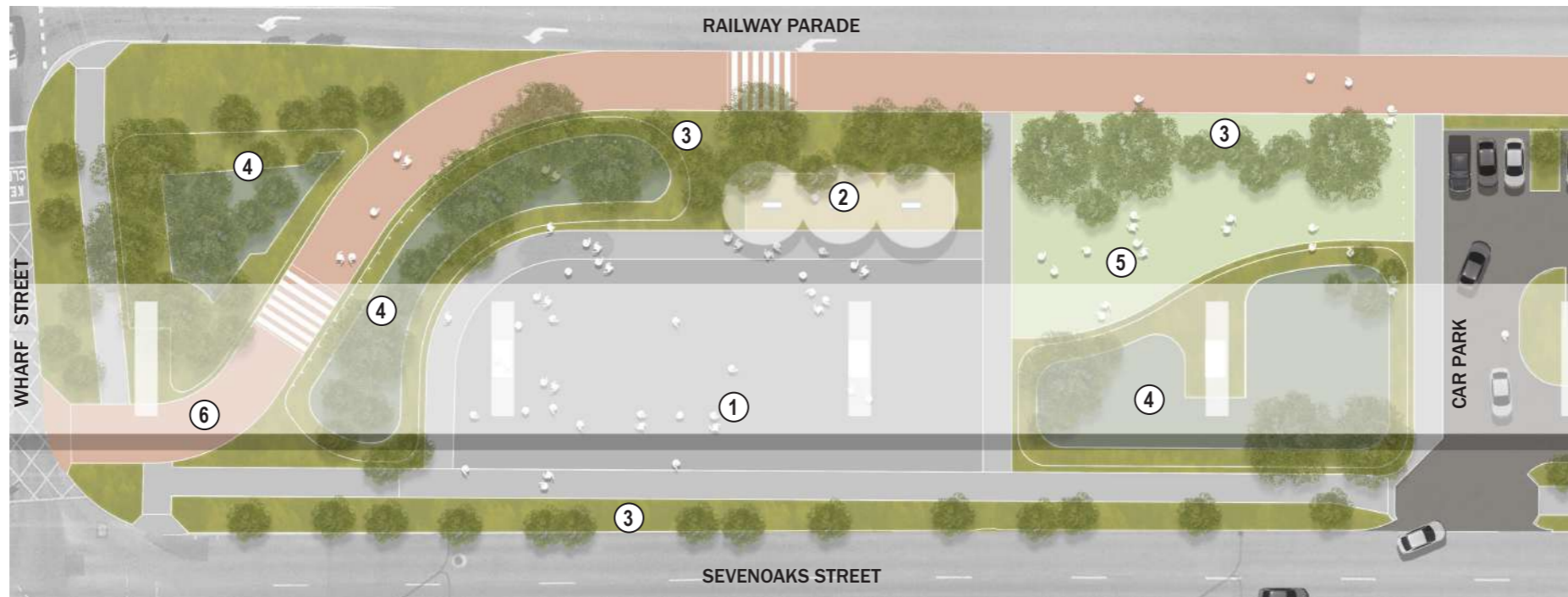

- ① Skate Park
- ② Chill zone - seating walls, shelters
- ③ Planted buffer
- ④ Drainage basin
- ⑤ Events Lawns
- ⑥ PSP

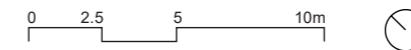

7.12 CANNINGTON CLIMBING AND BASIN

URBAN BOULDERING WALLS

Bouldering Wall

Adjacent to the bike store, short term car park and drop off bays, seating provides ample opportunity for various uses - cyclists getting their gear organised, climbers resting, watching or waiting for your ride.

A stand alone bouldering wall activates this space any time of the week in response to community feedback which indicated high support for this element.

The bouldering element sits on rubber soft fall. It is colourful and fully customizable, allowing interpretation of the station identity provided by Metronet Noongar Reference Group - the black cockatoo.

Basin Space

This drainage basin with circular boardwalk anchors the space with abundant planting, rainfall storage and seating, back dropped by a beautiful mural on the abutment wall.

Natural play elements (boulders and logs) provide informal play opportunities for kids waiting nearby.

Visual and pedestrian connection across the corridor is provided with legible interface to car parks, Sevenoaks and Railway Parade.



- ① Bouldering wall (standalone)
- ② Steps
- ③ Bike Store within the station
- ④ Drop-off bays
- ⑤ Universally accessible walkways
- ⑥ Principle shared path
- ⑦ Boardwalk
- ⑧ Seating built into boardwalk
- ⑨ Immersive play elements
- ⑩ Mural on abutment wall (Black Cockatoo interpretation)
- ⑪ Cross corridor connecting path
- ⑫ Planted drainage basin

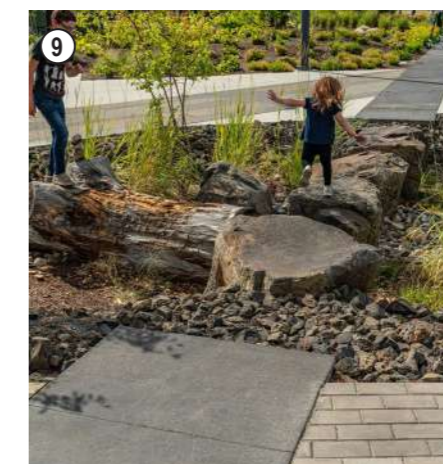
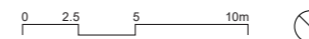

08 ENVIRONMENT

8.1 SUSTAINABILITY STRATEGY

Sustainability is at the centre of design decisions. The project includes a number of sustainability strategies, some of which we are sufficiently developed to highlight.

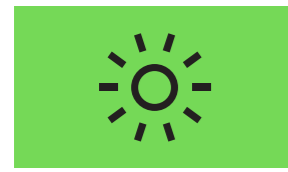

Respond to site conditions



Urban Forest / Ecology



Target zero waste



Water Sensitive Urban Design



Encourage and support physical and mental well-being



Provide active transport



Provide adaptable, flexible and resilient spaces



Undertake life cycle assessment and whole carbon modelling

Sustainability Initiatives Along the Length of the Linear Park

Rigorous Tree Management Plan for existing tree retention and protection. Drawings submitted as part of DA1.

Developing local plant + tree palettes based on endemic vegetation complexes, six seasons planting, expert advice, advanced procurement, habitat provision, and existing contextual urban forest species.

Shade and heat mapping completed.

Mapping tree planting constraints - offsets from structures, PSP, utilities etc. Assessing against canopy coverage targets.

Utilize structures for shade. Mapping sun / shade study to inform planting design.

Reviewing parking, and pedestrian circulation against shade studies and rain shadow.

Rigorous Tree Management Plan for existing tree retention and protection.

Mapping of urban forest context complete

Development of tree planting palette and design underway

Mapping sun / shade study to inform planting design

Developing local plant + tree palettes based on endemic vegetation complexes, six seasons planting, expert advice, advanced procurement, habitat provision, and existing contextual urban forest species.

Mapping tree planting constraints - offsets from structures, PSP, utilities etc. Assessing against canopy coverage targets.

Exploring potential re-use of waste materials on site e.g. concrete rail sleepers, rail ballast (as gravel/mulch/sub base).

Transplant select grass trees on site, re-use all fallen logs, rocks + boulders within the landscape.

Exploring potential to reduce infiltration basin media / spoil + imported fill.

Exploring potential to re-use site mulch and soil for re-use. Soil testing underway.

Extensive use of rain-gardens and infiltration basins throughout project.

Majority of water from viaduct, stations and retained rail sections being diverted in infiltration basins and recharging the ground water.

Water from structures to feed planting and reduce irrigation water use.

Exploring potential to reduce infiltration basin media / spoil + imported fill.

Many community activation and recreation spaces now documented.

Ongoing engagement with community reference groups, Local Government authorities and stakeholders.

CPTED strategy in place. Safety + access strategies being updated and feeding into design / documentation.

PSP strategy updated and full cycling infrastructure now documented.

Engagement with Cyclewest and community reference groups ongoing. Endorsement of design forthcoming.

Strategy for modal hierarchy now fed into the design and fully documented to provide + prioritize ample pedestrian and cycle paths, bus stops/ interchanges.

Create flexible spaces that can adapt to a variety of uses and events.

Use robust materials that respond to the site conditions.

Avoid or minimise use of dark hard surfaces to reduce radiant heat and urban heat island effect

ESD consultant undertaking lifecycle assessment and whole carbon modelling.

8.2 GREEN STAR

Green Star is an internationally-recognised Australian sustainability rating and certification system that will be applied to the project.



METRONET sustainability areas and themes

People and Place (Social)

Environment

Economy

METRONET sustainability areas and themes

Governance
Connectivity, Amenity, & Liveability

Environment Values & Biodiversity
Water
Resource Efficiency
Energy & Carbon

Procurement & Supply Chains
Workforce
Viable Communities

Application

The Green Star rating will apply to many different areas across the project.

Bus stops & interchanges

Services and amenities

Platforms and concourse

Station Structures

Car parks & footpaths

Landscape & other design elements

Landscape and public realm application within Urban Precincts

Concept Review

Site Planning and Layout

Urban Design and Public Realm

Collaborative engagement process with local community
Design review with OGA
Engagement with local indigenous communities
Engagement with diverse cultural groups in the area

Water Sensitive Urban Design
Native plantings
Enhancing the micro climate
Reducing the heat sink

Creating spaces that bring community together to make strong and viable communities
Telling local community stories
Placing activity nodes and destinations with existing local shops and schools

8.3 TREE PLANTING

Tree Planting Strategy

The project recognises that trees are a core aesthetic and environmental component of the sites urban landscape. They influence air quality, reduce urban heat, provide health benefits, manage storm water and many other advantages.

The approach to tree planting across the precincts is based on the following principles:

- Develop a planting palette that responds and reinforces the design narrative and framework - **Collective, Connected and Specific**. Refer Planting Palette section for further details.
- Retain exiting mature trees where possible, particularly those with heritage significance.
- Reinforce the existing adjacent streetscape planting in consultation with the individual LGAs.
- Use robust Australian native trees for shade to parkland and station forecourt areas.
- Add an overlay of local tree and understorey species endemic to the site vegetation complexes.
- Utilise trees where possible to create green volume and screening to minimise scale and visual impact of viaduct from surrounding residents.
- Respond to the Town of Victoria Park's Urban Forest Strategy and work with the Council Officers to inform the delivery of the tree planting across the site area.

The following tree planting section will provide further information on:

- Existing trees
- Proposed trees
- Tree planting offsets and brief requirements

Adjacent is a summary of the current and proposed site coverage of tree canopy.

Tree stats summary

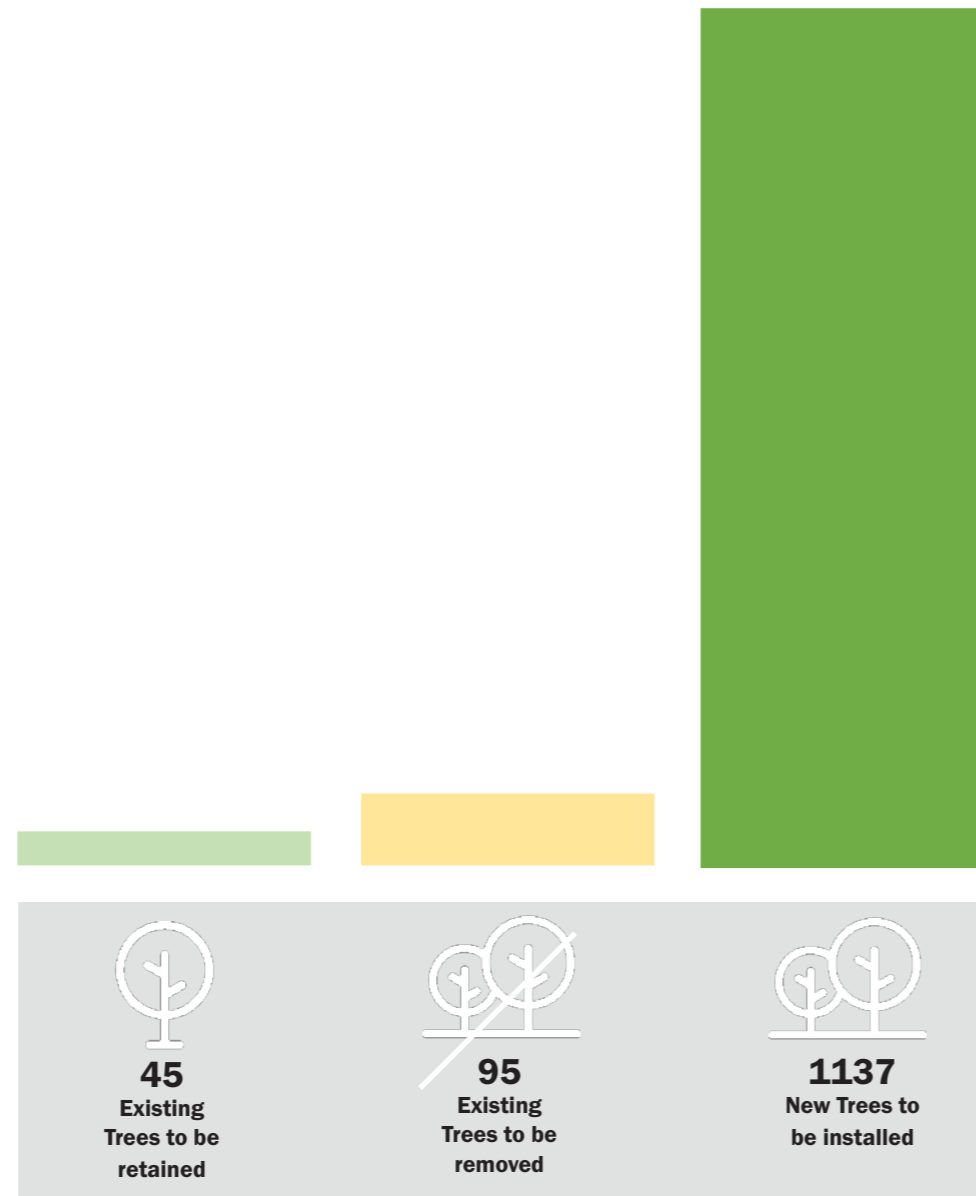

Calculation based on complete site area (not just planning control area)

Canopy Cover Summary

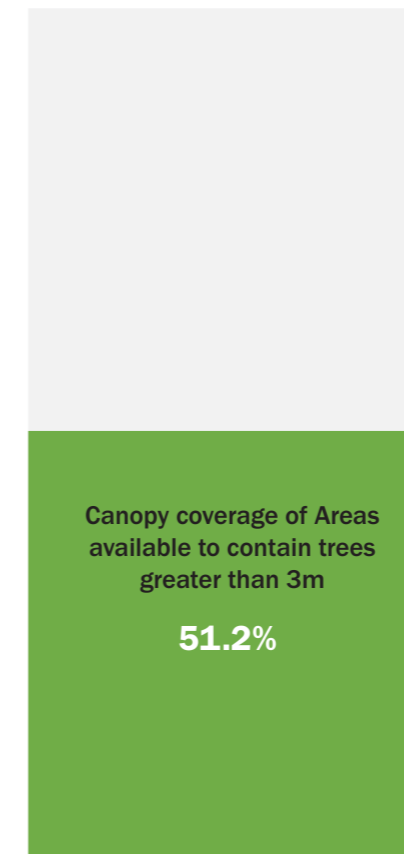

Available site area is calculated using project extent area excluding areas of infrastructure and offsets.

8.4 EXISTING TREES

Tree Protection and Retention

The majority of the existing trees within the site area lay within the council verge areas. The rail corridor itself has very little canopy cover.

The project has engaged a qualified arborist to map, record and assess all the existing trees across the site area.

The trees have then been assessed for protection based on the following criteria:

- Species
- Health
- Size (height, canopy width, TPZ + RPZ)
- Structure
- Useful life expectancy
- Habitat value
- Black cockatoo foraging species
- Native / exotic
- Valuable / weed species

It is the projects objective to retain as many existing trees as possible. Extensive design review & coordination has been undertaken and is ongoing with all design and construction disciplines to achieve minimal tree removal.

The tree protection and retention plans adjacent form part of DA1.

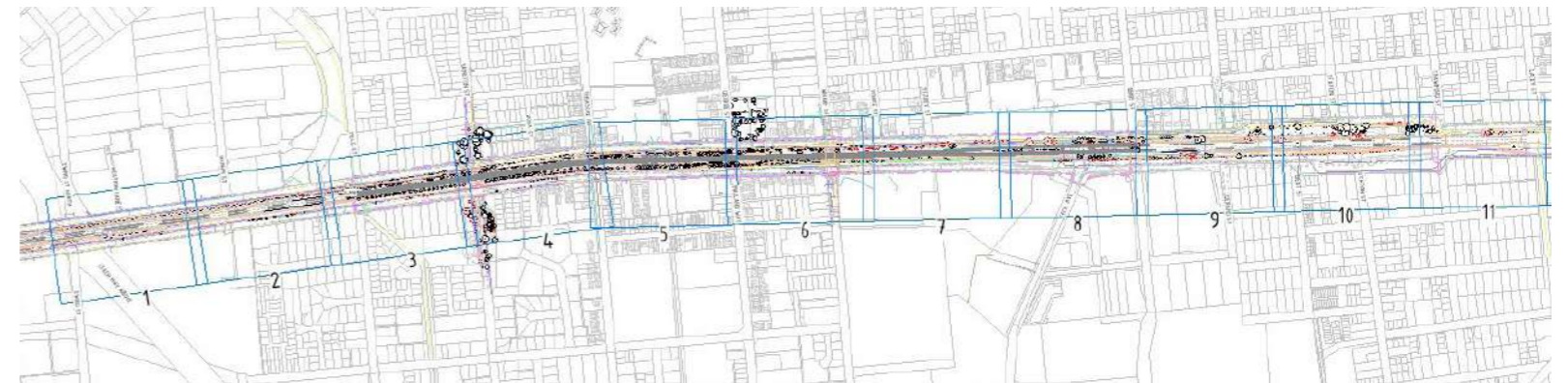

Overview of Package 2 Tree Management Plans

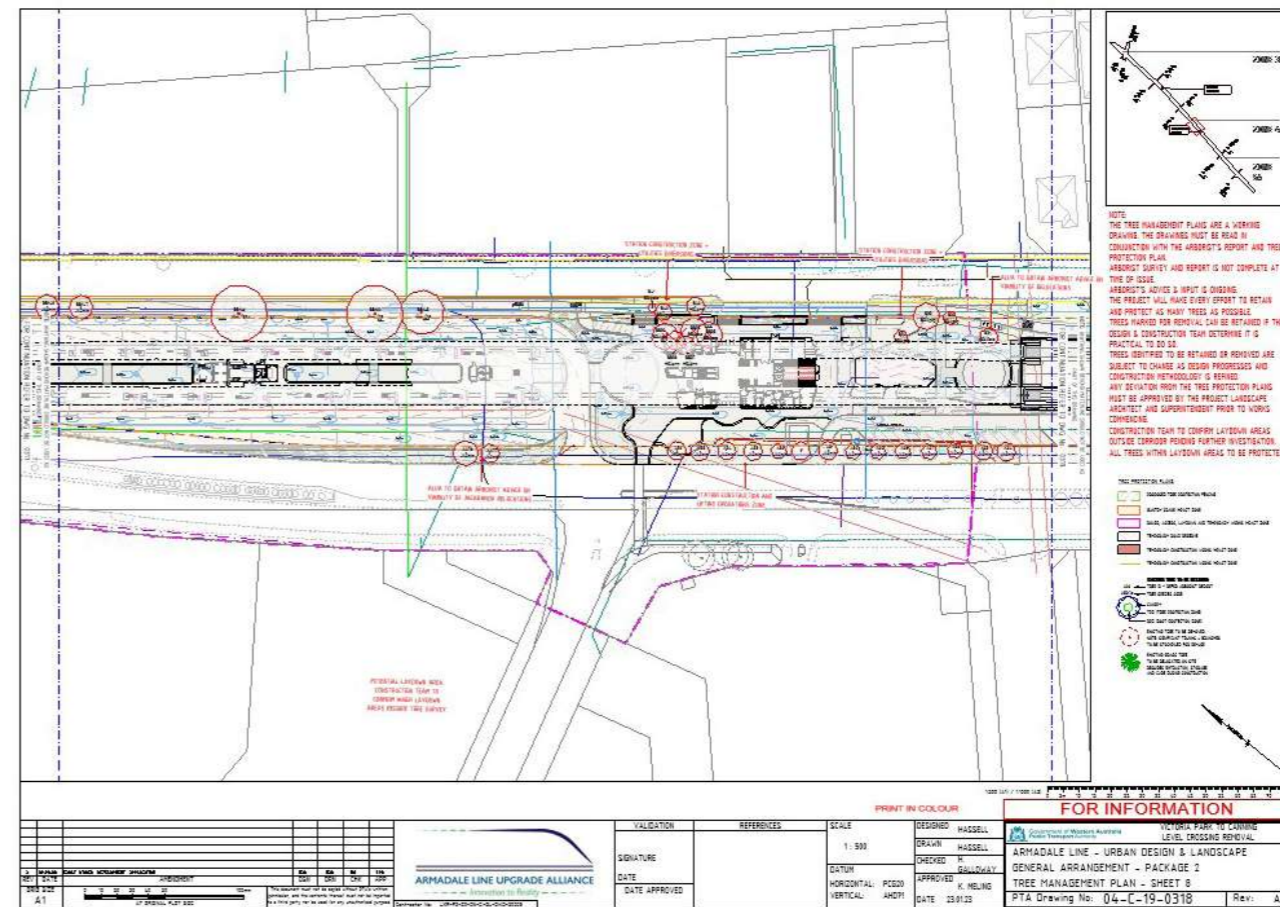

Example sheet - Cannington Station

Mapping Existing Trees to inform proposed tree species palette

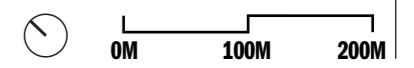
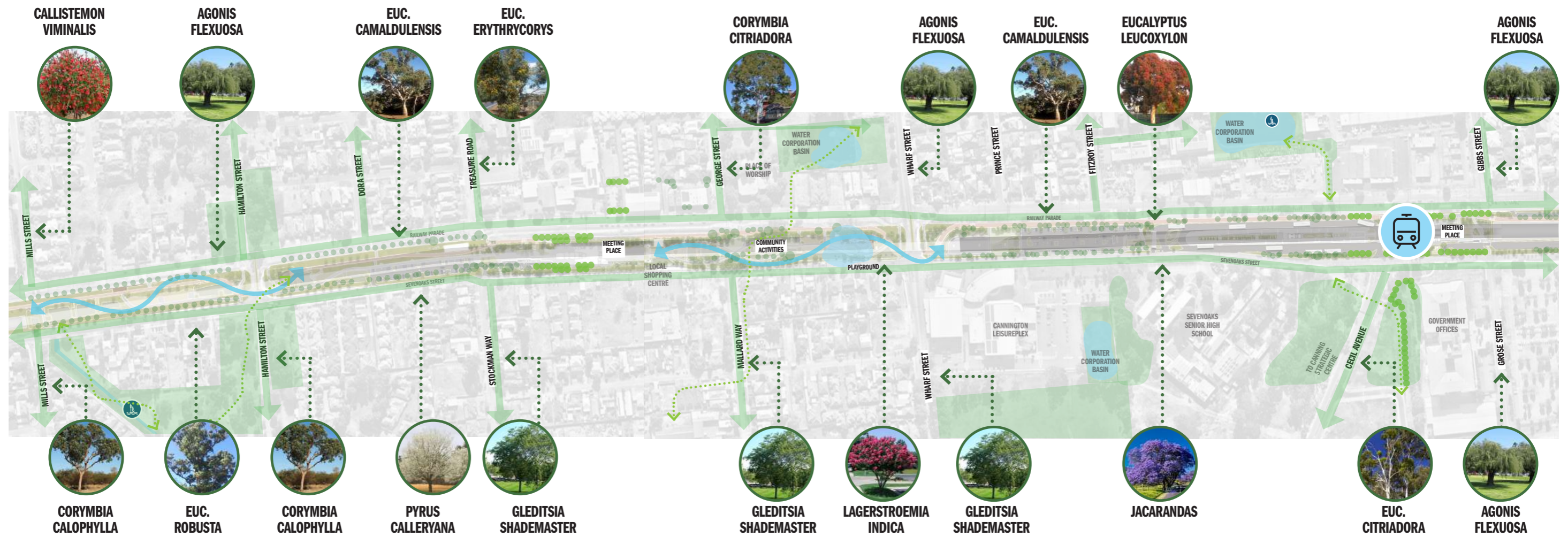

8.5 PROPOSED TREES

Tree Planting Strategy

The tree planting palette responds and reinforces the design narrative and framework - **Collective, Connected and Specific.**

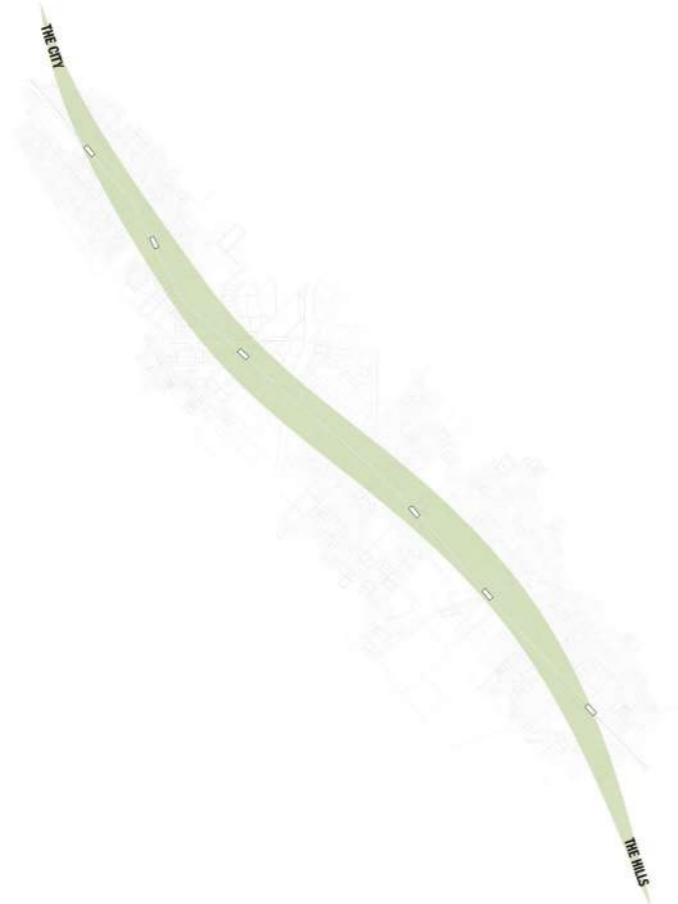

COLLECTIVE

Unifying native corridor trees

A palette of robust native corridor trees and understorey that will create structure and a sense of unity across the project length.

A single palette of tree species that run the project length.

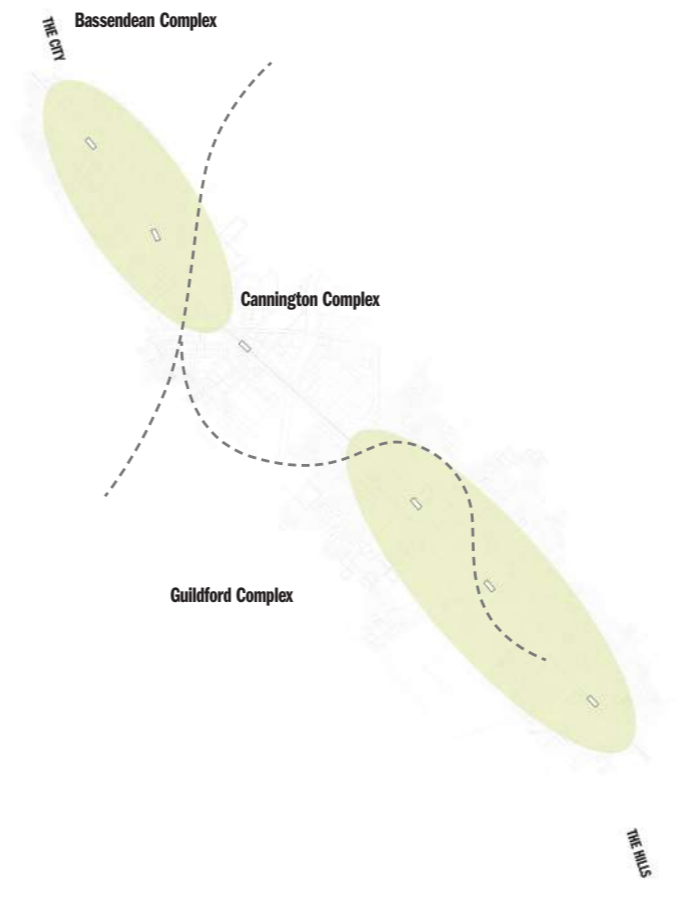

CONNECTED

Sense of place through vegetation complexes

A palette of native trees and understorey that is based upon the site vegetation complexes. Bassendean Complex to the Oats Street Package (north) and Guildford Complex to the Wharf Street Package (south).

Two palettes of tree species specific to the northern and southern corridors that reinforce the unique character of each.

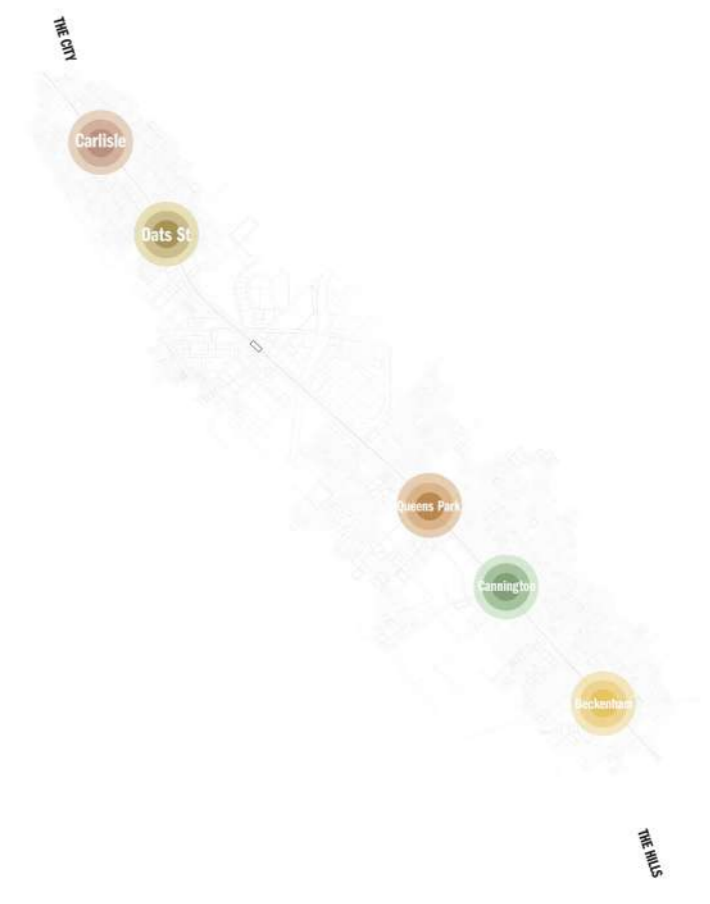

SPECIFIC

Signifier tree species that reinforce identity and wayfinding.

A palette of iconic and specific trees and plants that will support the individual station identity and interpretive and cultural narrative. Exotic tree species may be used if they reflect the vernacular streetscape character specific to the station location.

A single tree species for each station.

Tree Planting Palette



Allocasuarina fraseriana



Eucalyptus marginata

Tree Selection Strategy

The tree species have been selected to respond to the following strategy:

- From the endemic planting complex of the site area.
- Meet the height requirements for planting proximity to rail and viaduct structures..
- Respond to the site narrative of Collective, Connected and Specific.



Banksia attenuata



Eucalyptus tottiana



Banksia grandis



Melaleuca preissiana



Melaleuca leucadendra



Banksia littoralis



Banksia menziesii



Melaleuca raphiophylla



Melaleuca Quinquinervia



Agonis flexuosa

SMALL	MEDIUM	LARGE
TREE HEIGHT <5M	TREE HEIGHT <10M	TREE HEIGHT <15M
BANKSIA MENZIESII BANKSIA ATTENUATA MELALEUCA CUTICULARIS	BANKSIA GRANDIS BANKSIA LITTORALIS EUCALYPTUS LANE-POOLEI MELALEUCA PREISSIANA EUCALYPTUS TODTIANA MELALEUCA RHAPHIOPHYLLA AGONIS FLEXUOSA MELALEUCA LEUCADENDRA ALLOCASUARINA FRASERIANA CORYMBIA FICIFOLIA	CASUARINA OBESA EUCALYPTUS WANDOO EUCALYPTUS MARGINATA EUCALYPTUS RUDIS CORYMBIA CALOPHYLLA BANKSIA PRIONOTES BANKSIA ILICIFOLIA

Tree Install Size

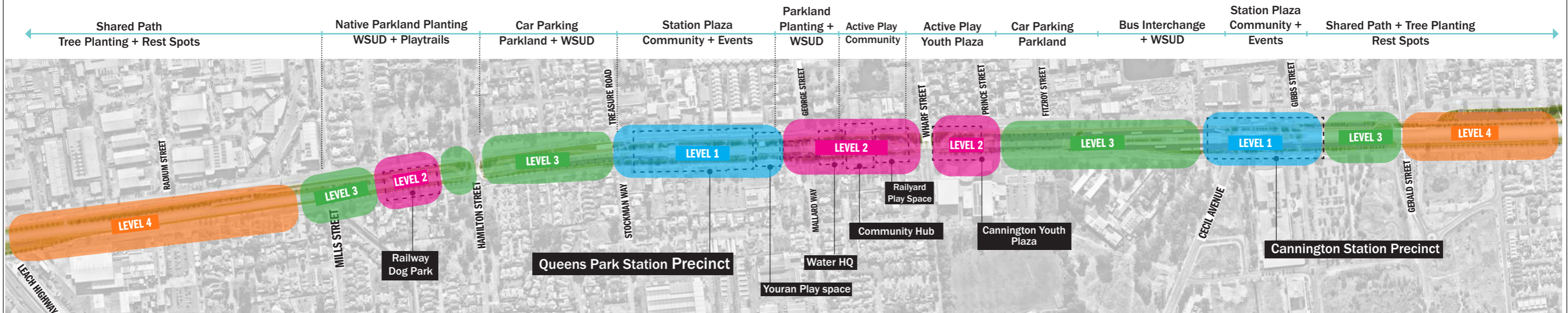

TREE INSTALL SIZE				
ZONE	APPLICATION	PERCENTAGE	POT SIZE	HEIGHT AT INSTALL
LEVEL 1	MINOR PLANTING	20%	100 Ltr	2.5-3.5m
	GENERAL TREES	50%	200 Ltr	3.5-4.5m
	GENERAL TREES	20%	500 Ltr	4.5-6m
	FEATURE TREES	10%	1500 Ltr	5.5-8m
LEVEL 2	EXTENSIVE PLANTING	50%	100 Ltr	2.5-3.5m
	GENERAL TREES	25%	200 Ltr	3.5-4.5m
	FEATURE TREES	25%	500 Ltr	4.5-6m
LEVEL 3	EXTENSIVE PLANTING	25%	100 Ltr	2.5-3.5m
	GENERAL TREES	75%	200 Ltr	3.5-4.5m
LEVEL 4	GENERAL TREES	75%	45 Ltr	1.5-2m
	FEATURE TREES	25%	100 Ltr	2.5-3.5m

All tree sizes and quantities subject to species selection and nursery availability.

Tree Install Size - Corridor

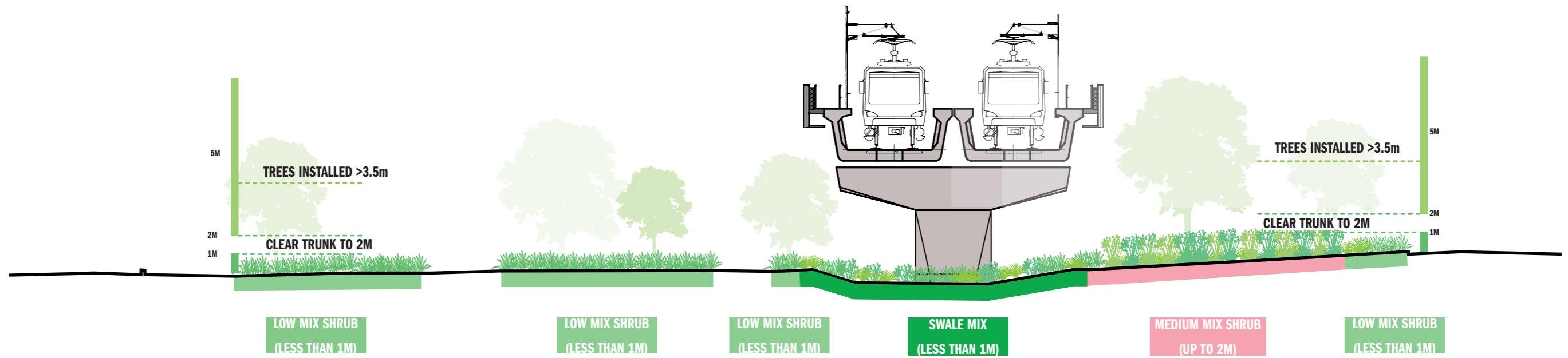

Tree Install Size - Station

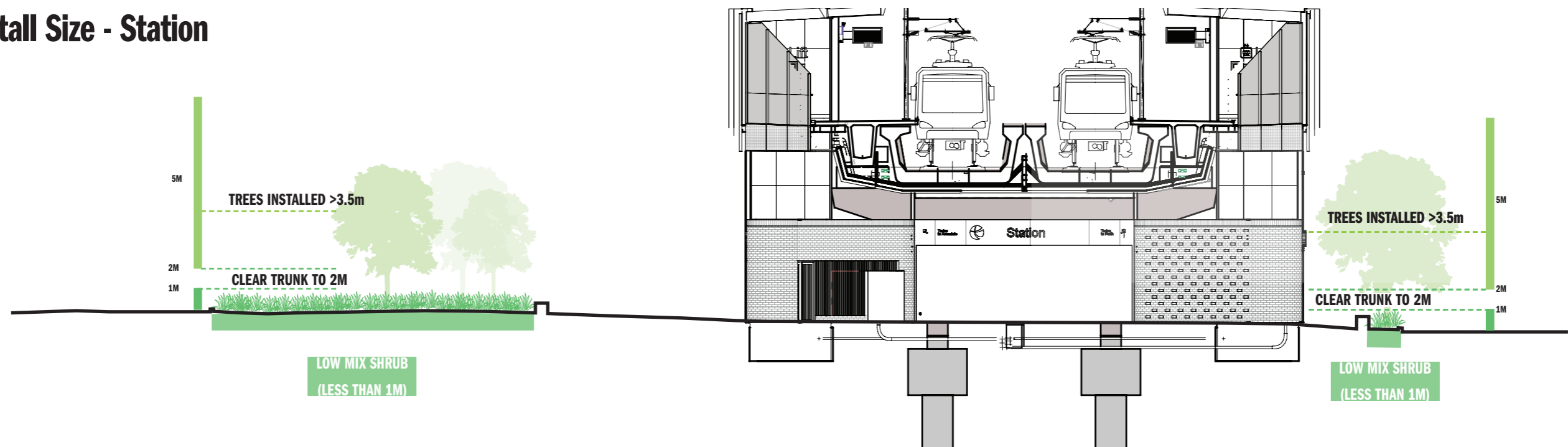

8.6 TREE PLANTING OFFSETS

At Grade

Tree Offset = Tree Height + 1M

Tree Planting Brief Requirements

The tree planting across the site has to comply with several different brief and offset requirements to ensure the protection of rail and utility services infrastructure.

Offset Requirements have been listed below as summaries over the following pages.

Rail Offsets:

- Mature tree height + 1m from overhead lines + running rail
- Offset reduced 1:1 (height : lateral offset) when rail is elevated.

Structure Offsets:

- No trees within 3m of structure
- Trees located 3-5m from structure to be species <10m tall at maturity
- Trees located 5-10m from structure to be species <15m tall at maturity
- Paved surfaces with hardstand + sub base surround station buildings (300mm deep)(typical 3-5m wide)
- Thickened paving sub-base to be installed (500mm deep compacted gravel trench) where trees are within 5m of station building

Utility Services Offsets:

- No trees within 1m (lateral distance from outside of pipe) of underground services - water, sewer, gas, power, comms or drainage infrastructure
- No trees within 1m (lateral distance) of access and inspection pits
- Water Corp Main:
 - Trees within 1-2m of a Water Corp main to be <5m mature height
 - Trees within 2-4m of a Water Corp Main to be <10m mature height
 - No trees from WC's not recommended species list

Primary Shared Path Offsets:

- No trees within 1.5m of PSP as per Aust Rds standards

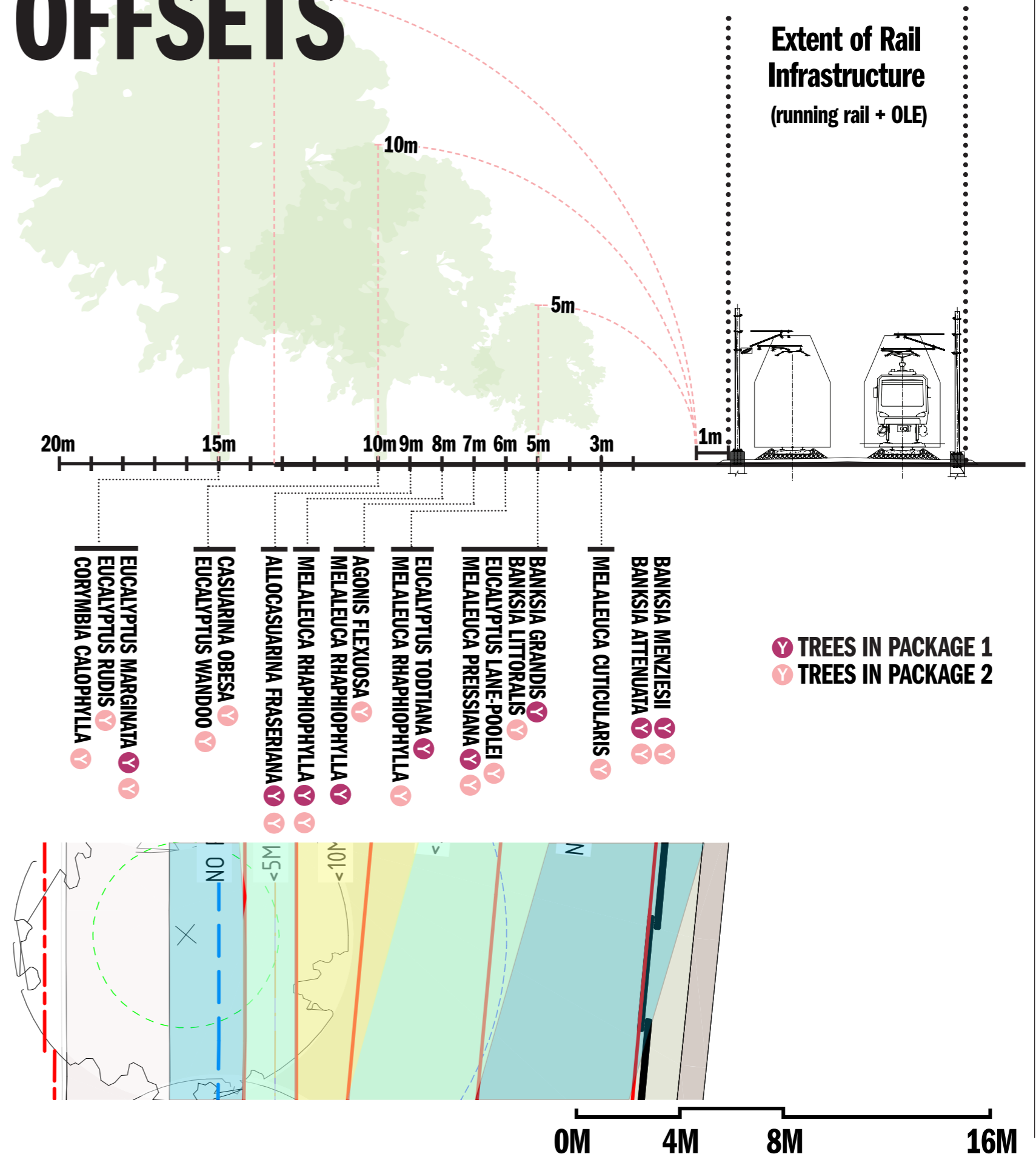

Typical Viaduct Section

Tree Offset = Tree Height + 1M - Viaduct Height

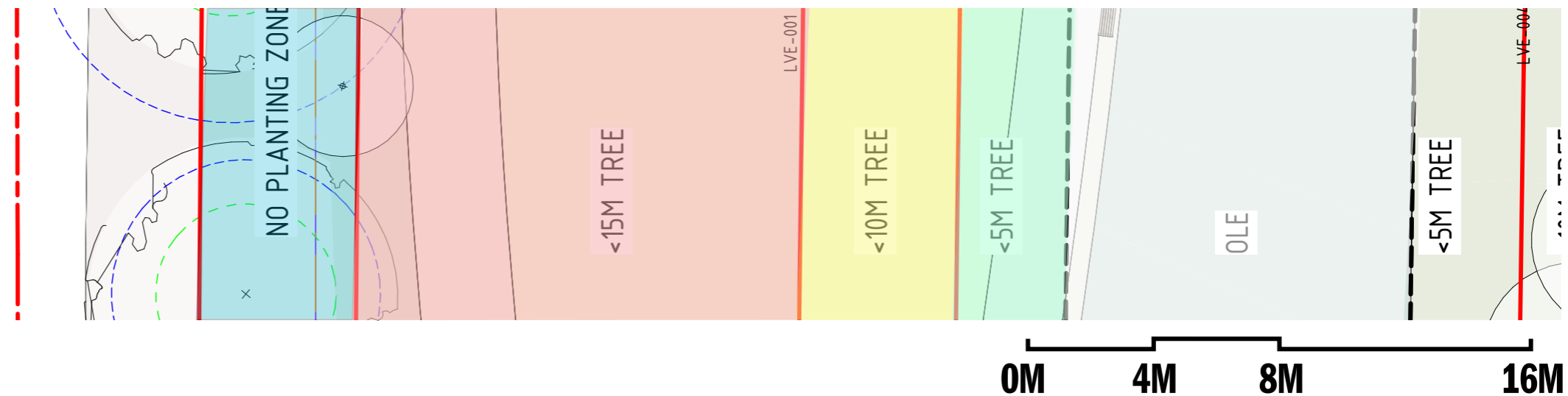
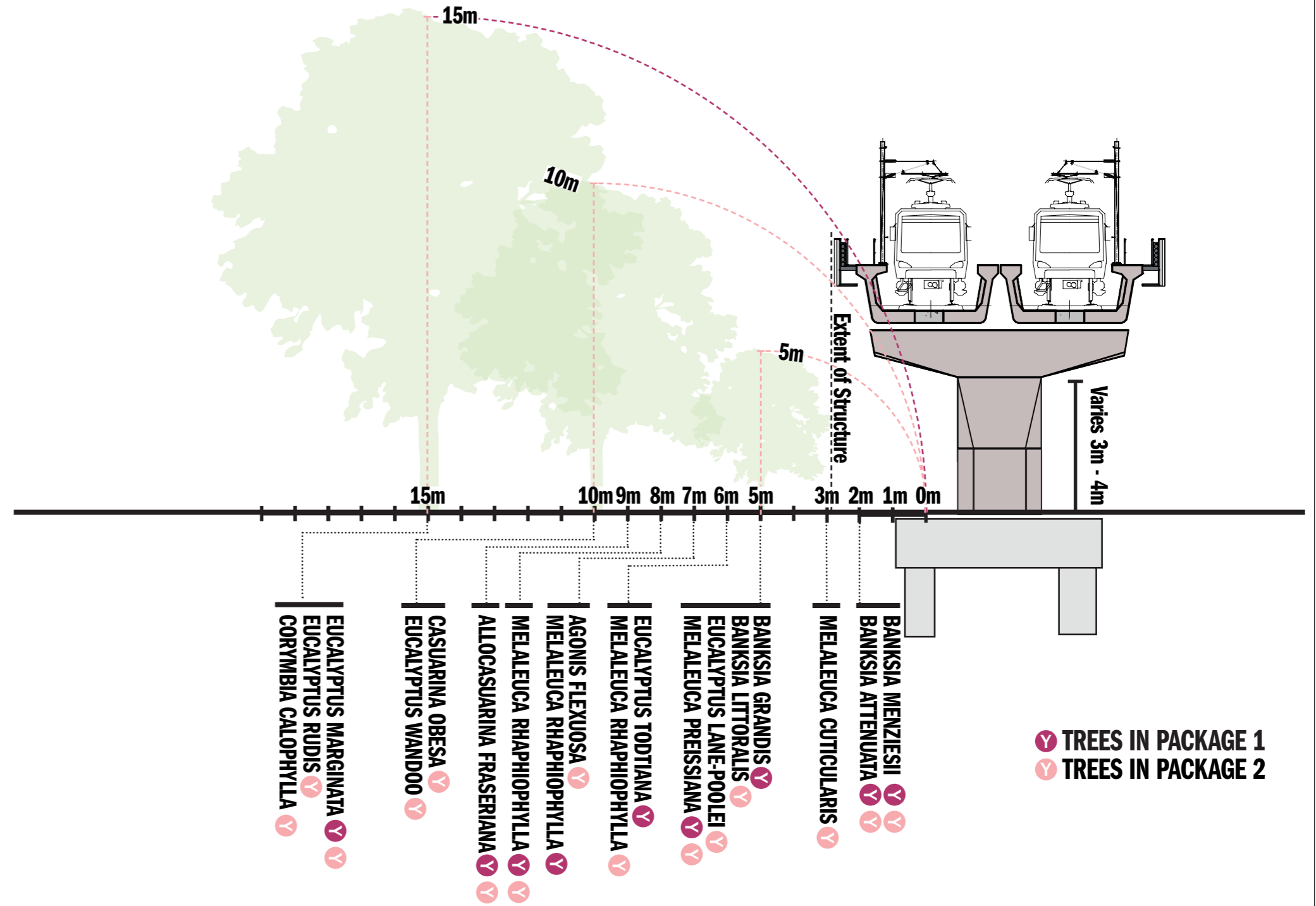

Building Section

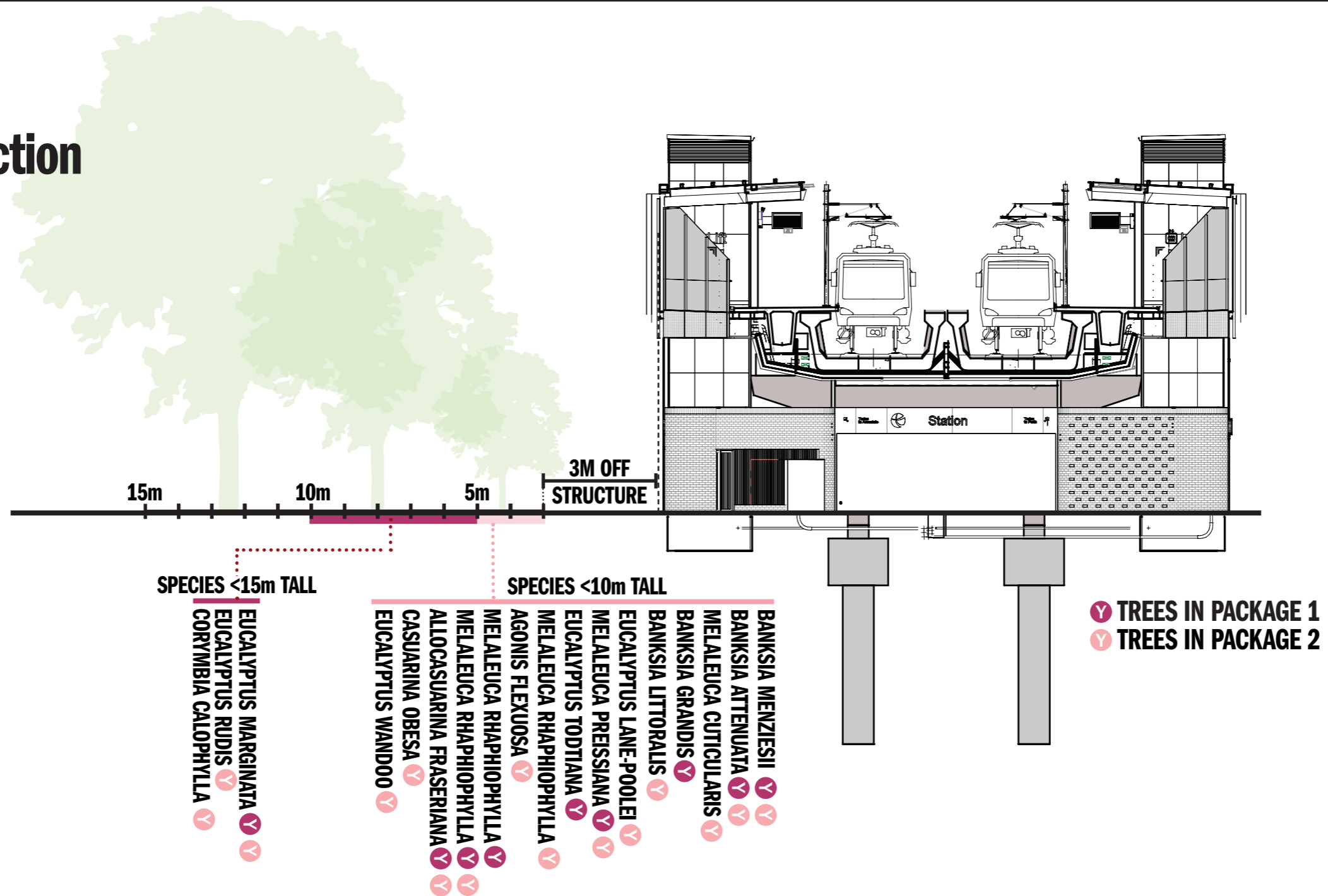

RUTLAND AVE

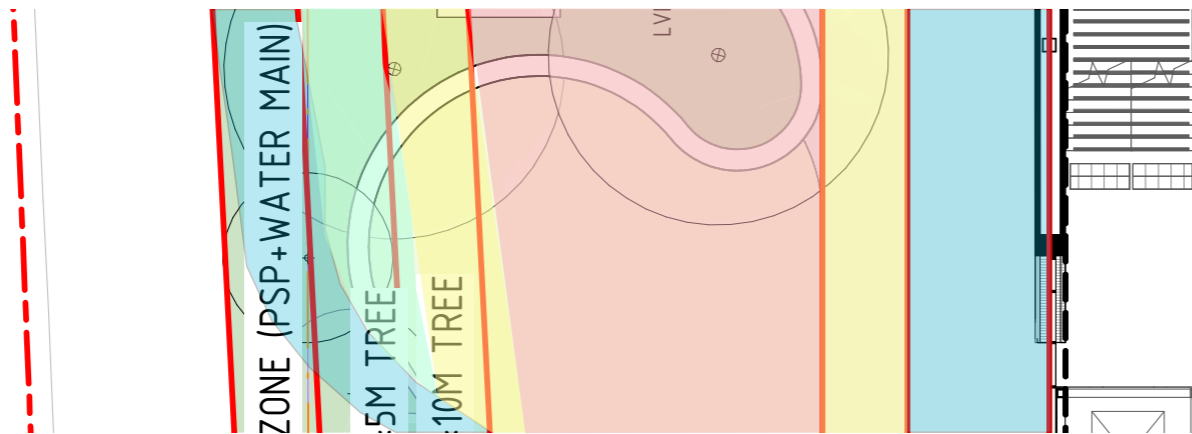

CARLISLE STATION

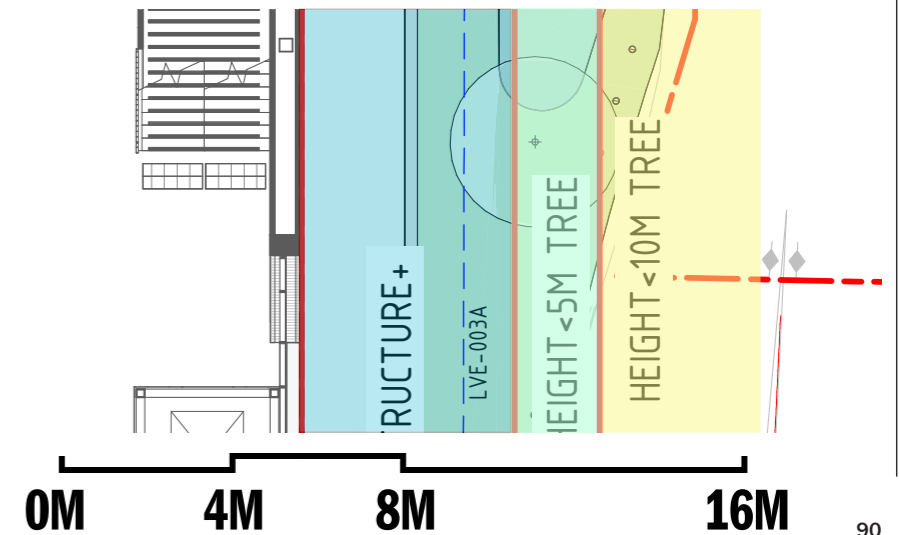

8.7 PLANTING STRATEGY

Creating a sense of "Abundance"

Through the planting and WSUD strategies the project will restore natural systems and processes. This intent aligns with the project narrative "Energy of Country" which refers to the cultural belief of spiritual energy created where flora and fauna are abundant.

Large areas of the project corridor will be planted with locally endemic vegetation complexes and native wildflowers. These diverse plant communities will provide opportunities for habitat creation and re-wilding of native fauna including insects, reptiles and birds.

The strategy requires that humans step back in certain portions of the corridor to allow areas to nature.

The approach to re-wilding design across the precincts is based on the following principles:

- Provide fenced areas with no public access (namely PTA corridor where rail is at grade). Concentrate rehabilitation seeding and planting within these zones.
- Consolidate areas of activation to station neighbourhood centres allowing the quieter parkland areas to encourage fauna and help to protect extensive planting areas from heavy use.
- Retain water on site and create Water Course Interpretations where possible to create a broad range of habitats.
- Identify project opportunities to the LGAs for community engagement and interpretation and education overlays.

Planting

The approach to softscape design across the precincts is based on the following principles:

- Develop a planting palette that responds and reinforces the design narrative and framework - **Collective, Connected and Specific.**
- Add an overlay of understory species endemic to the site vegetation complexes.
- Support the local endemic planting with robust Australian native planting in more heavily trafficked locations.
- Utilise planting for screening where appropriate - retaining walls, noise walls and embankments.

- Carefully create a shade tolerant planting mix for under viaduct areas.
- Provide planting palettes and planting densities that respond to the level of investment and surrounding use:
 - 'Premium' palettes in primary locations such as station plazas.
 - 'High' palettes in high profile locations such as bus hubs, activation nodes and key pedestrian movement paths.
 - 'Standard' palettes to spaces such as car parks and streetscape.
 - 'Simple' palettes to extensive parkland areas which lie between activity nodes.
- Provide a mix of native seeding and tubestock planting to rail corridor areas within PTA fence line areas.
- All turf areas to be installed to LGA requirements.

Wildflower Strategy

Wildflower planting is proposed throughout the corridor to both provide a sense of identity, seasonal change and cultural narrative.

The project will take learnings from the Wildflower Capital initiative to showcase the unique local flora in the design and character of the parkland and plaza areas of the project.

Procurement

The procurement of trees and planting for this project will need careful planning - the following strategies will be further investigated during the next phase of the project:

- Create a pre-procurement strategy to ensure trees are procured early to ensure availability and variety across the project.
- Consult industry specialists to ensure a robust planting palette that meets the requirements of the PTA and LGAs.
- Minimise species substitution through close consultation with nurseries through the design phases.
- Test under viaduct plant mixes for suitability prior to mass planting.

SHOWCASE WA's UNIQUE WILDFLOWERS

ENCOURAGE RETURN OF NATIVE FAUNA



REESTABLISH ENDEMIC VEGETATION COMPLEXES



CULTURAL AND SEASONAL CHANGE

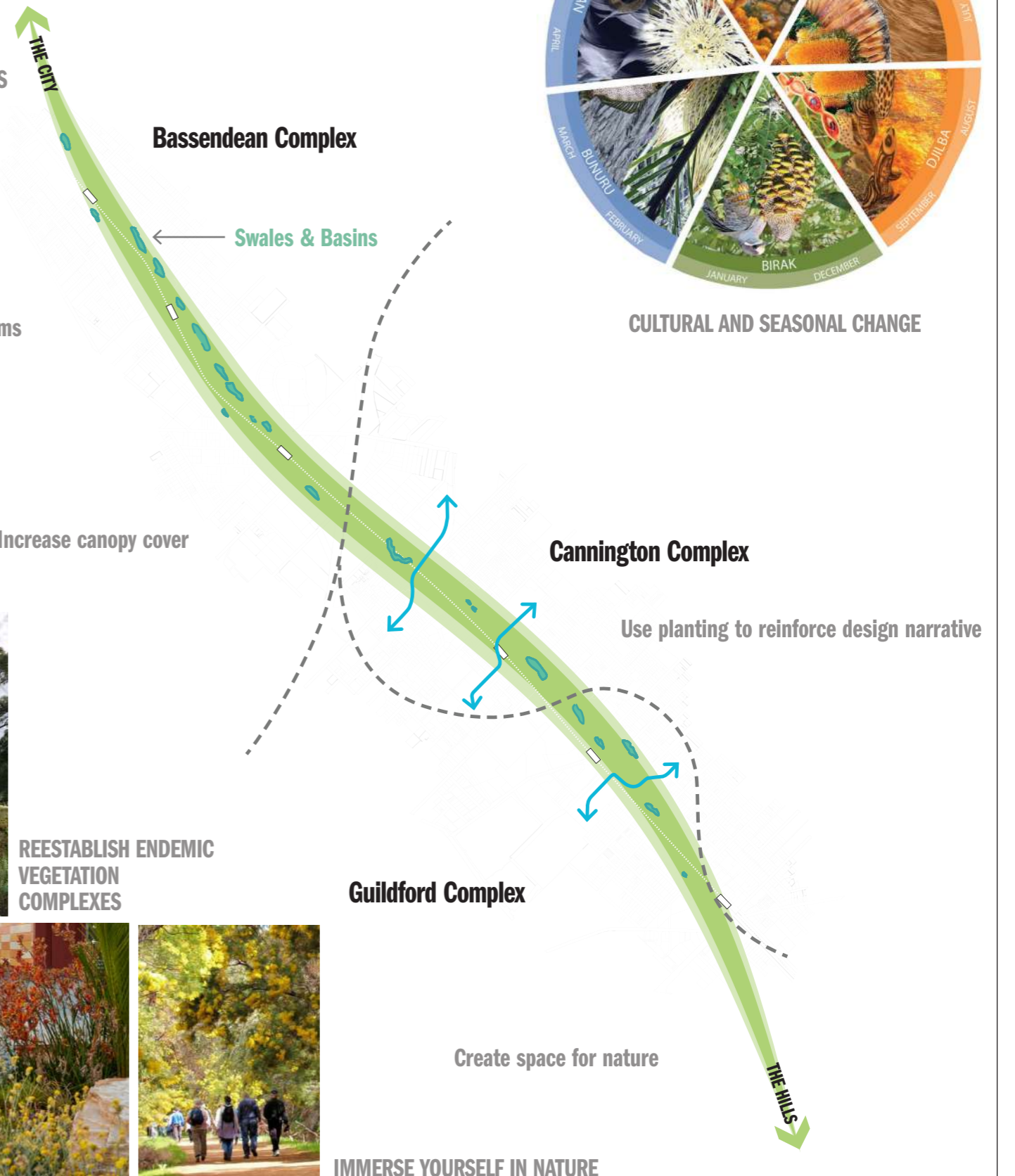

8.8 SHADE STUDY

Shadow Diagram

Creating a robust and site responsive planting palette

For each station the sun and shadow diagrams have been undertaken to inform the planting strategy. The alignment of the new stations and viaduct structures impacts the plants selected and their optimal location.

SHADE STUDY

21 DECEMBER

SUN HOURS BETWEEN 9AM - 5PM

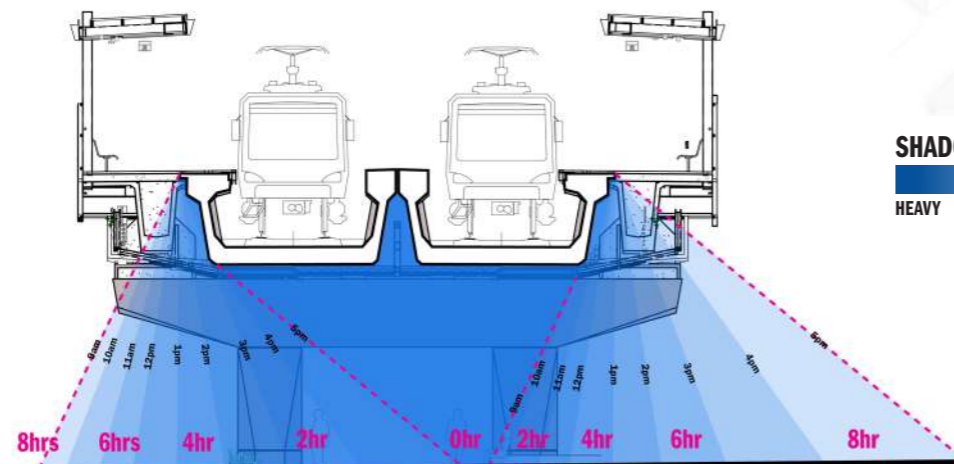
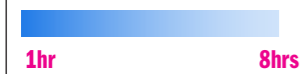

21 JUN

SUN HOURS BETWEEN 9AM - 5PM

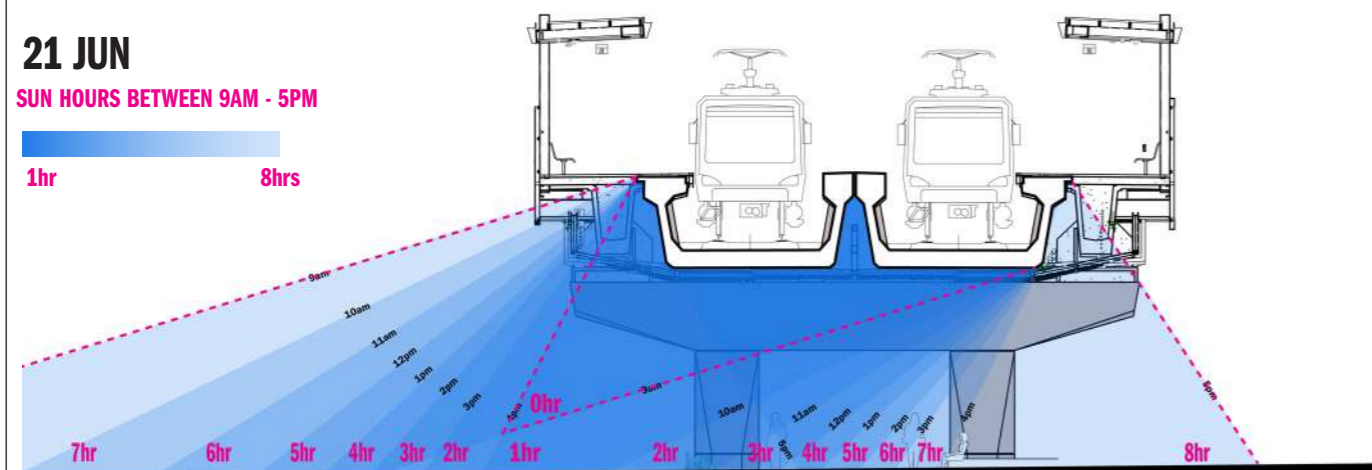
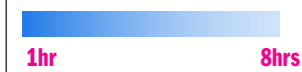

SHADOW DIAGRAM (WHOLE YEAR)

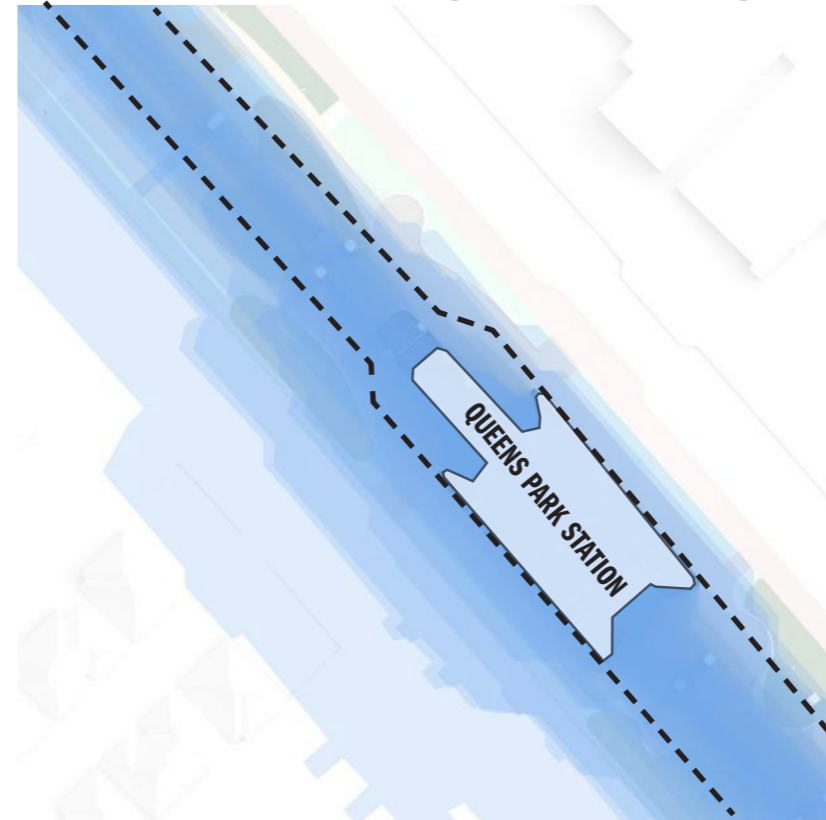

PLANTING DIAGRAM

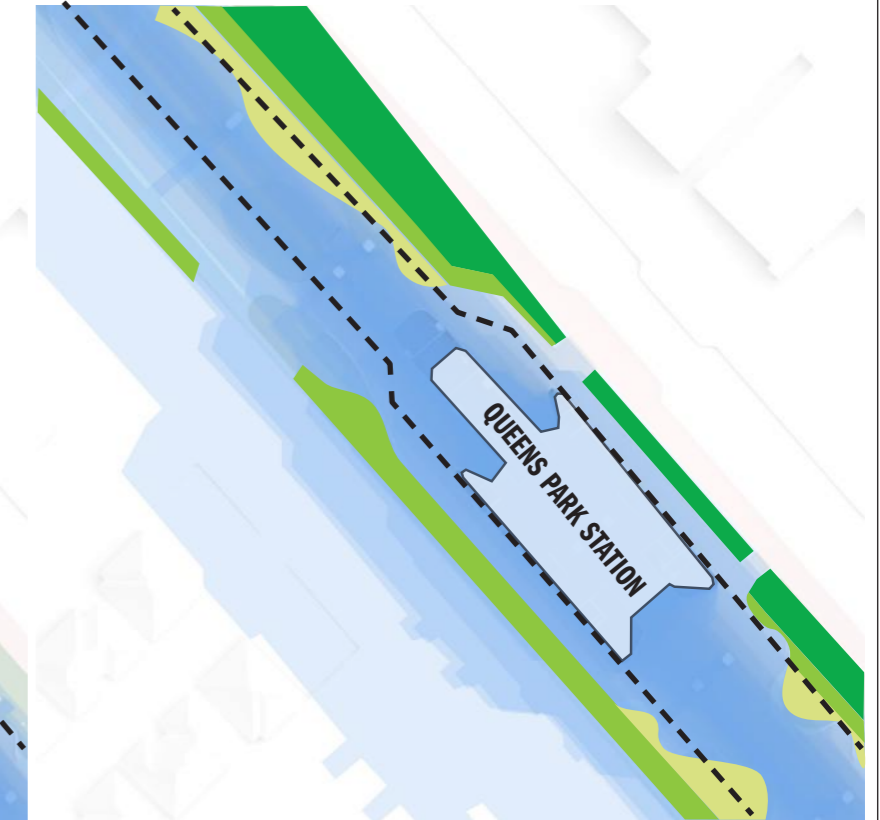

- FULL SUN PLANTING
- HALF SUN PLANTING
- FULL Shade PLANTING

SUN STUDY

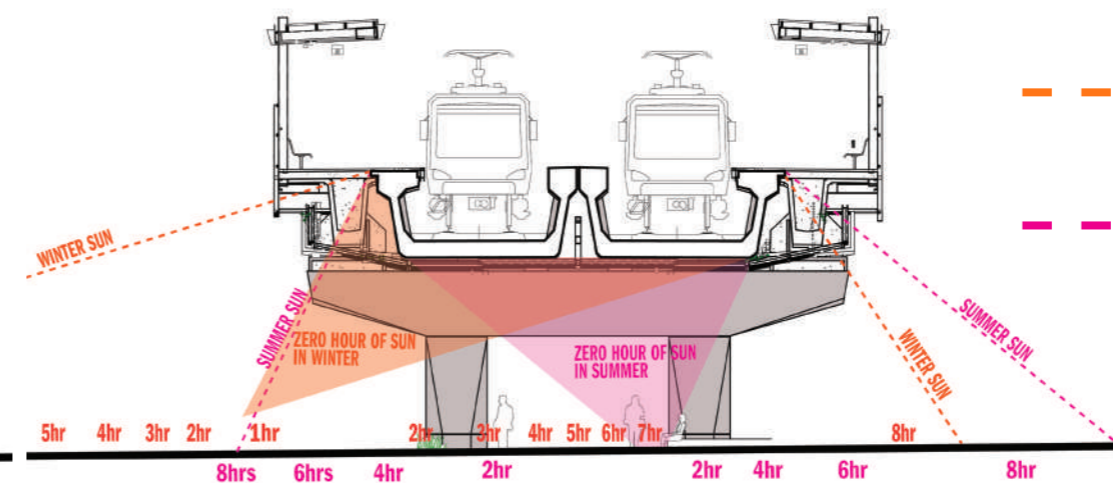

- — — **21 DECEMBER (SUMMER)**
SUN HOURS BETWEEN 9AM - 5PM
- - - **21 JUN (WINTER)**
SUN HOURS BETWEEN 9AM - 5PM

8.9 PLANTING STRATEGY

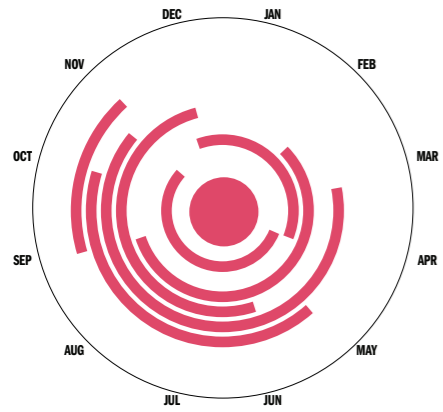

CARLISLE

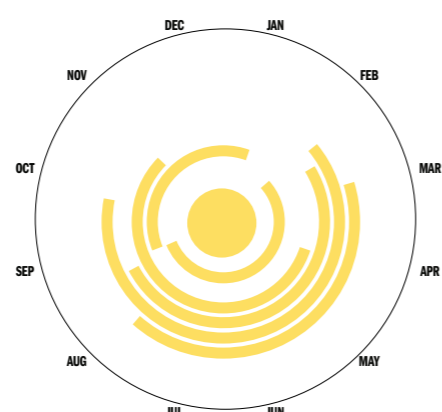

OATS STREET

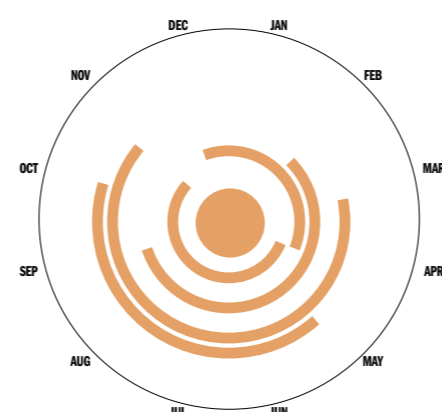

QUEENS PARK

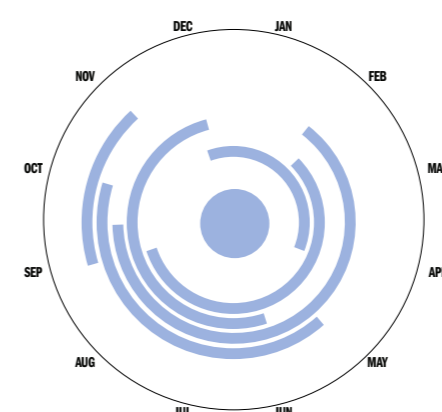

CANNINGTON

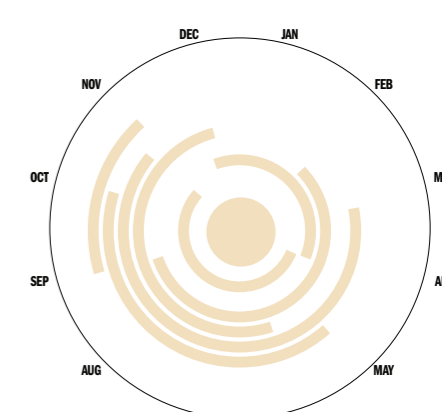

BECKENHAM



DAPPLED APPROACH



8.10 PLANTING PALETTE

GUILDFORD COMPLEX PLANTING



☀️☀️
Acacia saligna* Prostrate
'Wattle'
<0.3m groundcover



☀️☀️
Gastrolobium nervosum
<0.8m shrub



☀️
Anigozanthos manglesii
'Kangaroo Paw'
<0.1m shrub



☀️☀️
Anigozanthos viridis
'Green Kangaroo Paw'
<0.5m shrub



☀️☀️
Beaufortia elegans
'Elegant Beaufortia'
<0.1m shrub



☀️☀️
Calothamnus quadrifidus prostrate
'Common Net Bush'
<0.8m shrub



☀️
Baumea juncea
'Bare Twig Rush'
<0.1m shrub



☀️☀️
Conostylis aculeata
'Cottonhead'
<0.5m shrub



☀️☀️
Brachyscome iberidifolia
'Swan River Daisy'
<0.4m shrub



☀️
Melaleuca lateritia
'Robin Redbreast Bush'
<2m shrub



☀️☀️
Hypocalymma angustifolium
'White Myrtle'
<1m shrub



☀️☀️
Conostylis candicans
'Bare Twig Rush'
<0.1m shrub



☀️☀️
Dianella revoluta
'Blue Flax-Lily'
<1m shrub



☀️
Kennedia prostrata
'Running Postman'
<0.1m shrub



☀️☀️
Melaleuca thymoides
'Thyme Honey Myrtle'
<2m shrub



☀️
Dampiera trigona
'Angled-stem Dampiera'
<0.5m shrub



☀️☀️
Hardenbergia comptoniana
'Native wisteria'
<0.3m shrub



☀️☀️
Dielsia stenostachya
<0.9m shrub



☀️☀️
Hemiandra pungens
'Snake Bush'
<0.3m shrub



☀️☀️
Hypocalymma robustum
'Swan River Myrtle'
<1.2m shrub



☀️
Eremophila glabra
'Emu Bush'
<0.3m shrub



☀️☀️
Patersonia occidentalis
'Native Iris'
<0.3m shrub



☀️
Melaleuca trichophylla
<1m shrub

GUILDFORD COMPLEX PLANTING - BASIN



☀️ ☀️
Banksia telmatiaea
 'Swamp Fox Banksia'
 <0.2m Shrub



☀️ ☀️
Melaleuca incana
 'Dwarf Honey Myrtle'
 <1m shrub



☀️ ☀️
Bossiaea eriocarpa
 'Common brown pea'
 <1m shrub



☀️
Ficinia nodosa
 'Knobby Club Rush'
 <1m shrub



☀️ ☀️
Juncus pallidus
 'Pale rush'
 <2m shrub



☀️ ☀️
Thysanotus multiflorus
 'Fringe Lily'
 <0.3m shrub



☀️ ☀️
Orthrosanthus laxus
 'Morning iris'
 <0.5m shrub

8.10 PLANTING PALETTE

BASSENDEAN COMPLEX PLANTING



Acacia saligna* Prostrate
'Wattle'
<0.3m groundcover



Anigozanthos humilis
'Catspaws'
<0.1m shrub



Anigozanthos manglesii
'Kangaroo Paw'
<0.1m shrub



Anigozanthos viridis
'Green Kangaroo Paw'
<0.5m shrub



Beaufortia elegans
'Elegant Beaufortia'
<0.1m shrub



Calothamnus quadrifidus prostrate
'Common Net Bush'
<0.8m shrub



Baumea juncea
'Bare Twig Rush'
<0.1m shrub



Conostylis aculeata
'Cottonhead'
<0.5m shrub



Brachyscome iberidifolia
'Swan River Daisy'
<0.4m shrub



Melaleuca lateritia
'Robin Redbreast Bush'
<2m shrub



Hypocalymma angustifolium
'White Myrtle'
<1m shrub



Conostylis candicans
'Bare Twig Rush'
<0.1m shrub



Dianella revoluta
'Blue Flax-Lily'
<1m shrub



Gastrolobium nervosum
<0.8m shrub



Melaleuca thymoides
'Thyme Honey Myrtle'
<2m shrub



Dampiera trigona
'Angled-stem Dampiera'
<0.5m shrub



Hardenbergia comptoniana
'Native wisteria'
<0.3m shrub



Dielsia stenostachya
<0.9m shrub



Hemiandra pungens
'Snake Bush'
<0.3m shrub



Hypocalymma robustum
'Swan River Myrtle'
<1.2m shrub



Kennedia prostrata
'Running Postman'
<0.1m shrub



Patersonia occidentalis
'Native Iris'
<0.3m shrub



Melaleuca trichophylla
<1m shrub

BASSEDEAN COMPLEX PLANTING - BASIN



☀️ ☀️
Banksia dallaneyi
 'Wattle'
 <0.3m groundcover



☀️ ☀️
Melaleuca incana
 'Dwarf Honey Myrtle'
 <1m shrub



☀️ ☀️
Bossiaea eriocarpa
 'Common brown pea'
 <1m shrub



☀️ ☀️
Burchardia congesta
 'Milkmaids'
 <0.8m shrub



☀️ ☀️
Juncus pallidus
 'Pale rush'
 <2m shrub



☀️ ☀️
Thysanotus multiflorus
 'Fringe Lily'
 <0.3m shrub



☀️ ☀️
Orthrosanthus laxus
 'Morning iris'
 <0.5m shrub

8.11 WATER SENSITIVE URBAN DESIGN

Storm water Strategy

Key initiatives behind the corridors sustainability design principle are to create an environment that both manages flood control and storm water run off, as well as increasing habitat and biodiversity.

The design response will provide best practice Water Sensitive Urban Design principles that include a range of benefits through the following interventions:

- Minimise pit and pipe infrastructure.
- Capture and store water in place as much as possible instead of relocating to large detention basins.
- Capture storm water run off from overhead viaduct and surrounding hard surfaces by incorporating harvesting and directional drainage solutions.
- Locate basins under the rain shadow of the viaduct minimising the need for irrigation.
- Provide safe basins along the corridor
 - max 300mm deep (water) in minor events where possible with shallow banks for egress within Station Precincts. Within public realm areas basins in accordance with IPWEA.
- Mitigate the requirement for fencing to all basins within the corridor and station precincts where possible (refer plan on follow pages for fence locations).
- Integrate storm water natural systems in a thoughtful and explicit way, providing opportunities for education and interpretation.
- Water use for irrigation will be focused on planted areas in the immediate vicinity of station or activity nodes, with the majority of planting to be un-irrigated.
- Strategically integrate WSUD into the urban and parkland environments to enhance user experience through

ecological diversity, amenity and activation opportunities.

- Establish rain gardens, swales and detention basins to capture, treat and restore ground water.
- Celebrate water as identified in the Place Plans and corridor narrative by responding to the natural environments surrounding water systems.

Design Development

Basins are currently designed to hold a maximum water depth of 300mm for minor rainfall events within Station Precincts. Within public realm areas basins in accordance with IPWEA. The sloped batters are typically 1:6.

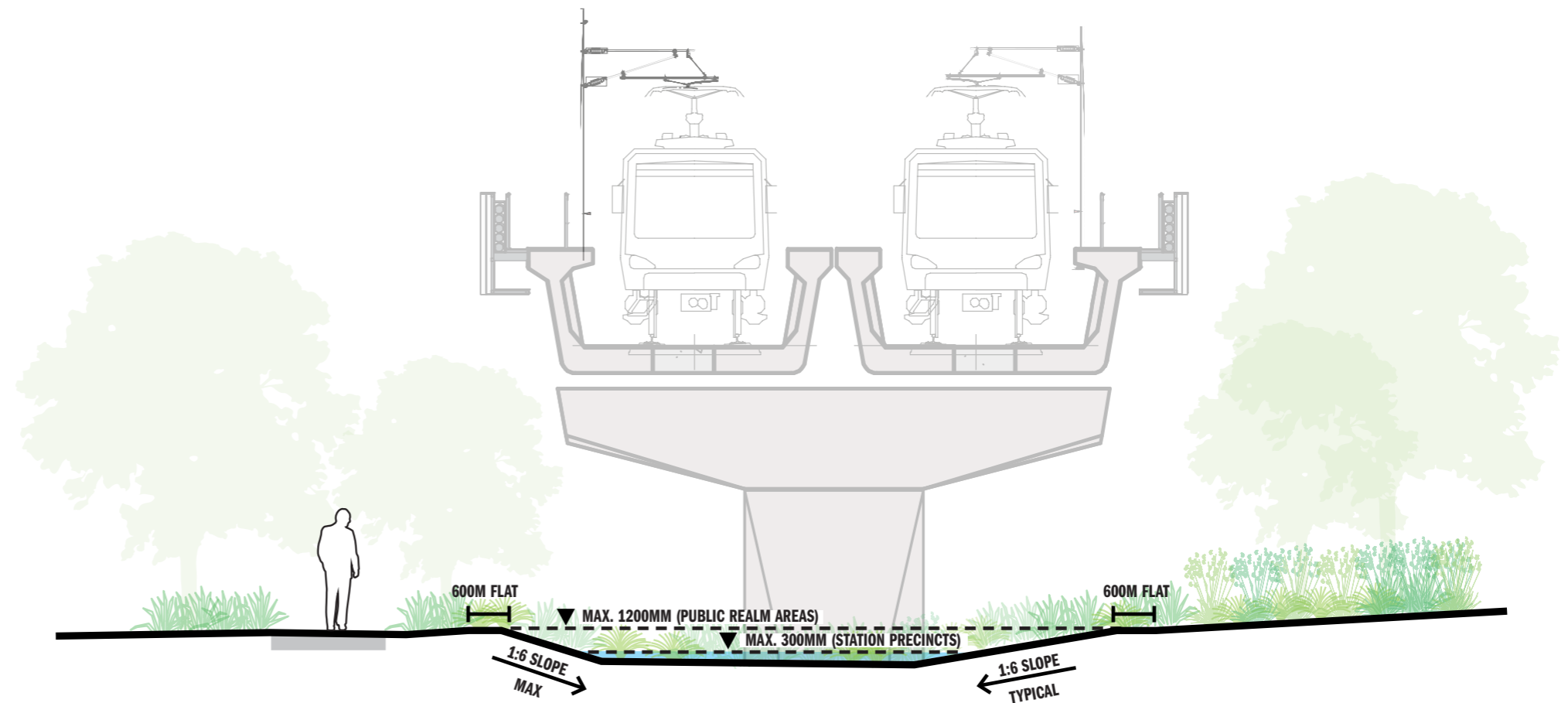

Typical Basin

Water the rain shadow of the viaduct

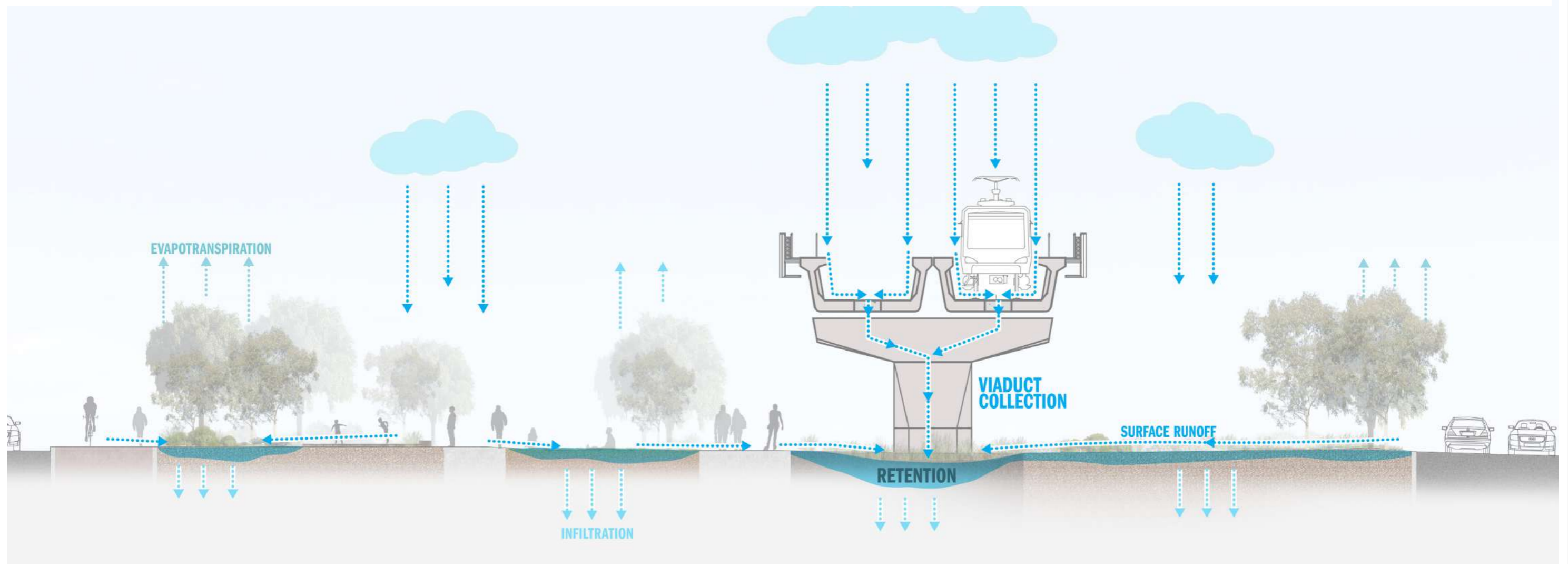
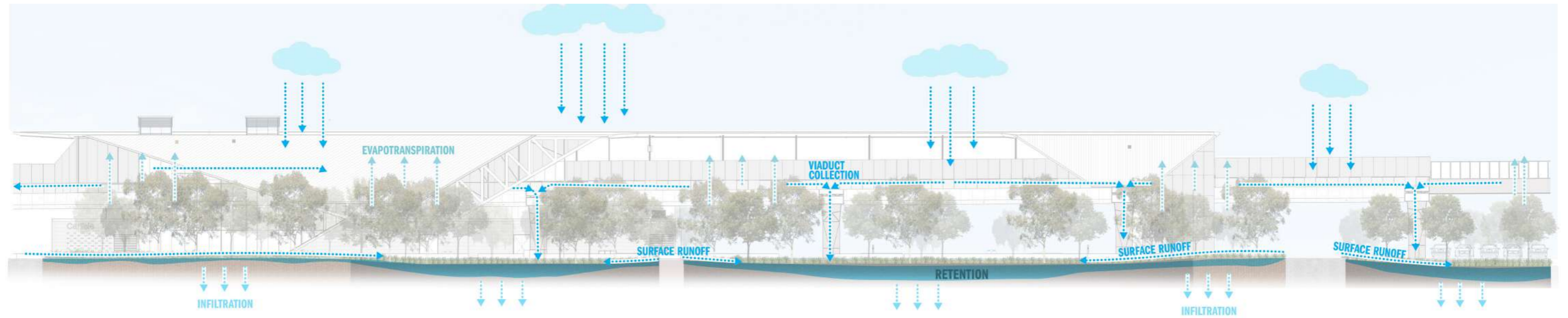

WHARF STREET PACKAGE

High water table with very low infiltration rates



Mill Street Drain

Opportunity to draw water from the Water Corporation drainage systems to support irrigation of the landscape works and improve Water Sensitive Urban Design outcomes (to be explored in collaboration with the City of Canning and Water Corporation).

Parkland Drainage and WSUD

Basins are aligned under the viaduct central to the corridor. Passive irrigation achieved within rain shadow of the overhead structure.

Drainage pit and pipe infrastructure minimised via direct outflows from the viaduct piers and overland flow from surrounding parkland to basins.

Car Parks

Water will sheet across car parks over flush kerbs into surrounding planting beds and raingardens to create passive irrigation whilst treating first flush rainfall where possible.

Queens Park Station

Some basins surrounding stations will require terraced walls and planting to achieve invert depths required.

These basins will still retain max depth of water as 300mm in minor events.

Seating walls and low planting surround basins to ensure ensure safety.

Water will sheet into basins from surrounding plaza hardscape areas to clean first flush rainfall.

Water HQ

The basins surrounding Water HQ educational zone are deeper and will be fenced appropriately (1.2m high non-climbable fence).

These basins form a chain of connected cascading basins which will provide passive irrigation to rain shadow areas under the viaduct.

Legend

 Basins in accordance with IPWEA with a max slope of 1:6 grade. Will appear as depressed areas of landscape planting outside of rainfall events.

Note: green zones on plan denote base of basin footprint.

 Basins with a slope steeper than 1:6 grade. Will appear as sunken areas of landscape planting outside of rainfall events.

These basins will be fenced with a min 1.2m non-climbable fence.

Note: blue zones on plan denote base of basin footprint.

 Shallow drainage basins with a terraced wall and planting embankment. Will appear as sunken areas of landscape planting outside of rainfall events.

Note: blue zones on plan denote base of basin footprint.

WSUD AND DRAINAGE STRATEGY SUBJECT TO ONGOING DESIGN AND DEVELOPMENT IN COLLABORATION WITH THE LGA

Wharf Street Drain

Opportunity to draw water from the Water Corporation drainage systems to support irrigation of the landscape works and improve Water Sensitive Urban Design outcomes (to be explored in collaboration with the City of Canning and Water Corporation).

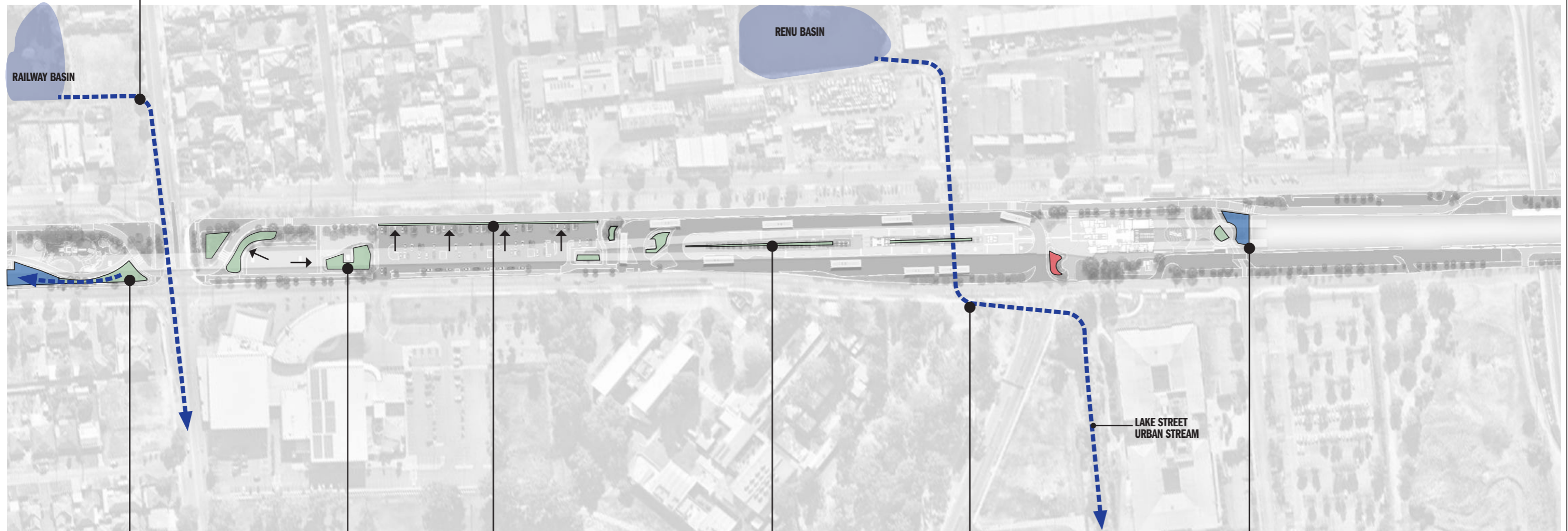

Play and Interaction	Youth Plaza	Car Parks	Cannington Bus Interchange	Renu Basin and Lake Street Urban Stream	Cannington Station
<p>Basins will include interactive opportunities such as timber steppers and fallen logs creating a necklace of informal paths and interaction for children. This will allow activation of these spaces outside rain events. Educational and interpretive overlays will be explored.</p>	<p>Basins will surround the Youth Plaza hardscape areas to allow overland flow into surrounding planting beds and swales to create passive irrigation and reduce drainage pit and pipe infrastructure whilst treating first flush rainfall where possible.</p>	<p>Water will sheet across car parks over flush kerbs into surrounding planting beds and raingardens to create passive irrigation whilst treating first flush rainfall where possible.</p>	<p>Central shallow swales and basins capture and treat water run-off from viaduct and platforms above.</p>	<p>Opportunity to draw water from the Water Corporation drainage systems to support irrigation of the landscape works and improve Water Sensitive Urban Design outcomes (to be explored in collaboration with the City of Canning and Water Corporation).</p>	<p>Basin to the south of Cannington Station will capture the majority of water from the Station platform and canopy. This basin will require a non-climbable fence. An adjacent smaller shallower basin will allow for integration of log steppers and informal play within the design.</p>

BASINS ARE WIDELY DISTRIBUTED ALONG THE LINEAR PARK

09 IDENTITY

9.1 INTERPRETATION

Integration of Interpretation

Authentically integrating a strong sense of place has been a core driver of the design approach. Each design decision has reflected upon the Collective, Connected and Specific themes. There are numerous opportunities for the interpretation of the cultural narrative along the length of the linear park including:

- Within the activity nodes the spaces can tell local stories of country
- Throughout the art strategy
- Interpretive signage can educate the community on ancient stories and modern places
- At each station through the choice of materials and colours

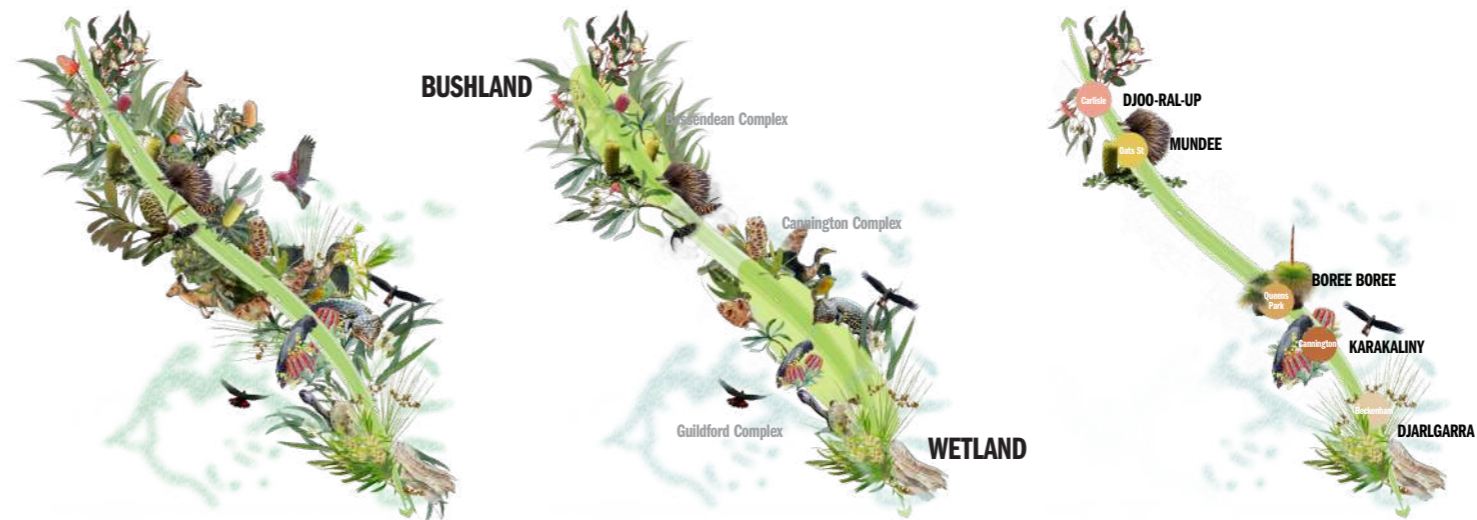

COLLECTIVE

Energy of Country

Revitalising living country
Abundance of Energy
Abundance of Life + Water

CONNECTED

Connection to Country

Noongar Whadjuk People's connection to Country
Deep Timetable
Custom, Lore + Language

SPECIFIC

Celebration of Place

Noongar Place Names
Stories of Place

INTERPRETATION

- SIX SEASONS PLANTING
- PLANTING COMPLEXES: BASSENDEAN, CANNINGTON, GUILDFORD
- RE-WILDING THE CORRIDOR
- REINSTATE NATURAL ECOSYSTEMS - WATER TREATMENTS, BASINS AND SWALES.

- SYMBOLS + MARKERS OF SAFETY (VIADUCT AND STRUCTURES)
- SEASONALITY + COMMUNITY GATHERING
- DIFFERENT LANDSCAPE CHARACTER
- THE BEELOO AND BIELIAR CLANS

- SPECIFIC STORIES OF PLACE
- TOTEMS
- PATTERNS + GRAPHIC STORY
- COLOURS

9.2 SITE CURATORIAL THEMES



TO INFORM:

- _Urban Design (Architecture and Landscape)
- _Art Strategy
- _Interpretation and Education

9.3 KEY OPPORTUNITIES

Dojoorolup - Carlise Station



Jarrah Trees

Mundee - Oats Street Station



Mundee / Echidna

Boree Boree - Queens Park Station

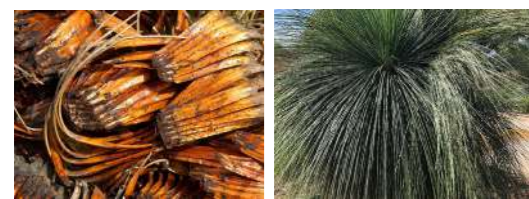

Balga Tree - Wide Open Plains

Karakaliny - Cannington Station



Red Tailed Black Cockatoo

Djarlgarra - Beckenham Station



Melaleuca / Paperbark

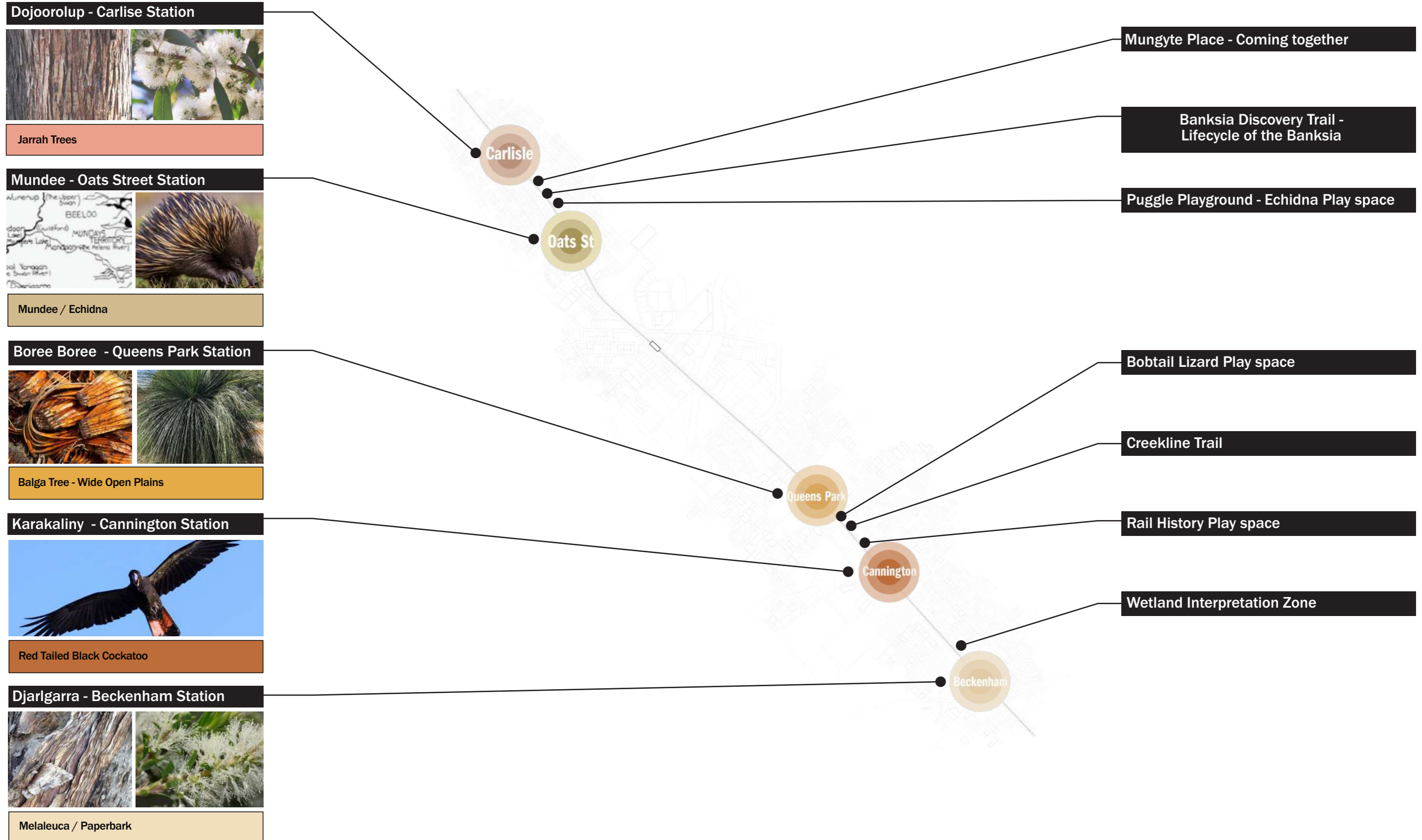

9.4 MATERIALS STRATEGY

HARDSCAPE PALETTE

Subject to refinement with LGA

Hardscape Palette

The paving palette has been developed to reinforce the Final Place Plans framework of Collective, Connected and Specific.

This will be further refined in collaboration with the Town of Victoria Park (ToVP) and to align with the cultural and interpretive narrative.

The final selection and design of the hardscape will be based on the following principles:

- The materiality of the precinct environs should reinforce the overall urban design character and complement the station materials and design.
- The palette should create a unified approach of materiality, colours and textures that respond to location and function.
- Pavements should reinforce wayfinding and hierarchy, prioritising pedestrians where appropriate.
- All paving should be robust and easy to maintain.
- Any maintenance access areas should be trafficable as per requirements of the stakeholders.
- Provide 'premium' pavements in primary locations such as station forecourts and plazas.
- Provide 'high quality' pavements in high profile locations such as bus hubs, activation nodes and key pedestrian movement paths.
- Provide 'standard' pavements to secondary spaces such as car parks and streetscapes.
- Provide 'simple' pavements to extensive parkland areas and cross connectors which lie between neighbourhood centres.

This page highlights the proposed range of pavements that will be reviewed and developed with the ToVP.

Material Interpretation & Features:



Site-wide Park Materiality



Station Plaza



Recreational Path



Secondary Paths



PSP - Asphalt



Compacted Gravel



Paving Joints



Art & Interpretation



Paving Selections

Pavement design will be used to create hierarchy of spaces, reinforcing dwell spaces, wayfinding and identity.

Interpretation and Wayfinding

Opportunities for interpretation will be explored within the pavements and be included within the Art Strategy.

FLOOR FINISHES

Subject to refinement with LGA



Premium Paving Type 1

Two types of engineered exposed aggregate concrete paving unit 600x300x60mm. Suitable for heavy vehicles (DFES and Façade maintenance vehicles as a minimum).



Premium Paving

In situ concrete pavements for primary and secondary paths.
 Primary: Exposed aggregate concrete (Medium Exposure) finish.
 Secondary: Broom finish concrete finish
 Colour and mix to be confirmed with ToVP.



Compacted Gravel

Stabilised Granitic Gravel. Mukinbudin 'Summerstone' Fines. Suitable for pedestrian traffic, light vehicle traffic and around new trees.



Shared Path

Principal shared path surface - Red Asphalt with line markings.



Shared Path (Approach)

Shared path surface at Station Approach - Omnigrip. Final selection of materials and colour to be coordinated with MRWA, PTA and LGAs.



Shared Path (Warning)

Principal shared path surface (Station Warning) - Omnigrip. Final selection of materials and colour to be coordinated with MRWA, PTA and LGAs.



Hard court Surface

Patterned Plexipave surface. Asphalt or concrete with Plexipave surface finish. Suitable for heavy vehicles. This is an applied finish to a standard black asphalt surface.



Rubber Soft fall

Coloured Rubber Soft fall. EPDM Coloured Soft fall Rubber - UV Stabilised via high polymer content and aliphatic binder (to manufacturer's specification). Allow for single and mixed colours.



Playground Mulch

Playground Organic Mulch. Jarrah wood chip to meet AS4422 and AS4685. Max 30mm diameter.



Concrete boardwalks

Permatrak or similar concrete boardwalk system. Powdercoated steel kickrails.

LANDSCAPE STREET FURNITURE & FIXTURES Subject to refinement with LGA

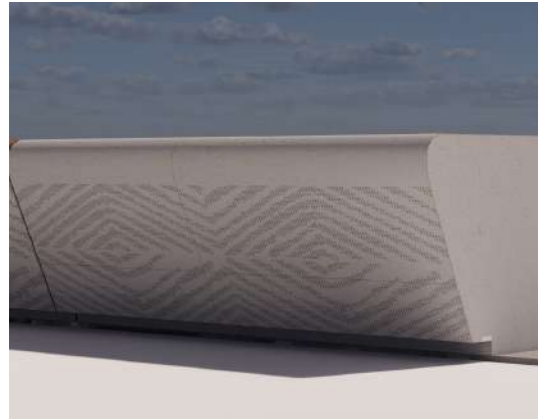

Concrete Seating Wall

Pre-cast Concrete Feature Seating Wall. Feature concrete with high quality finish, and lighting. Station Forecourts.

Pattern to be included as part of the Art Strategy



Concrete Plinth Seating Wall with batten top

Seating wall with batten top surface. Concrete plinth. Frame: Stainless Steel 304. Battens: Aluminium Wood-grain.



Stainless Steel Bicycle Racks

Stainless Steel Bicycle Racks. Cora - CBR1 B 316 stainless steel with electro-polish finish. Sizing :800Hx850W



Precinct Drinking Fountain

Drink Fountain with refill station. Urbanff - Apollo 280, with longer basin (AS1428 compliance), Tap & dog bowl. Stainless steel tray, nozzle, push buttons.



Standard PTA Stainless Steel Bin

Perforated stainless steel bins, slot pattern stainless steel finish. Sub-surface fixing, installation as per manufacturer's recommendations.



Precinct Dual Bin Enclosure

Recycling bin and Rubbish bin. Painted Steel.



Bollard Type 1 – Fixed

Stainless steel. Proprietary stainless steel bollard. Leda Security 150NB stainless steel bollard – SSP150FP68B. Permanent in-ground marine grade 316 stainless steel bollards. 900H at nom 1250 centres.



Bollard Type 2 – Retractable

Stainless steel. Proprietary stainless steel bollard. Leda Security 150NB stainless steel bollard – SSP150RSC.



Bollard Type 3 – Parkland

Bollard Type C – Parkland. Recycled Plastic. Replast 145mm Bollard. Profile: Pyramid Top.



Seat

Seat. Frame: Stainless Steel 304. Battens: Aluminium wood-grain. Name: "Linea Seat".

LANDSCAPE STREET FURNITURE & FIXTURES Subject to refinement with LGA



BBQ

Double All Access Electric Barbecue. Stainless steel. A Series – A2-E - Christie



Bench

Bench. Frame: Stainless Steel 304. Batters: Aluminium wood-grain.



Table Setting

Table Setting. Frame: Stainless Steel 304. Batters: Aluminium wood-grain



Concrete Mounted Bench

Plinth Fixed. Frame: Stainless Steel 304 Batters: Aluminium wood-grain.



Shade Shelter

Customised shade shelter.

NOTE:

Shade shelters currently under development in collaboration with the Design Working Group and the LGA. The further development will align with the general intent of the concept image below and will achieve an appropriately high level of detailing and design quality.



Bus Shelter

Customised bus shelter.

NOTE:

Bus shelters currently under development in collaboration with the Design Working Group, PTA and Transperth.

10 MOVEMENT

10.1 MOVEMENT STRATEGY

Circulation and Access

The majority of existing Principle Shared Path (PSP) adjacent to Rutland Street is retained to allow separation of commuter cyclists and other recreational users. Vegetated buffers and alignment on the eastern edge of the corridor minimizes conflict points.

Entries to commuter car parks, and bus interchanges are therefore located on the western side of the corridor (Banks Street), again to minimize conflict points between cars and cyclists. This arrangement is supported by the pedestrian access report, traffic assessment, universal access report and community engagement feedback.

The recreational shared paths form a network of connecting routes forming "Neighbourhood Loops" along the length of the corridor. These loops allow flexibility on how far a user can walk and allow multiple versions of the same journey.

A large majority of benchmark linear parks reviewed had single paths meaning people would walk the same path in both directions. These neighbourhood loops allow you to walk a different path each time.

This recreational path network is created using a variety of path types to facilitate different users and create a hierarchy of movement.

Hierarchy:

1. PSP - refer next page.
2. Recreational Shared Path (RSP) - this is a 3m wide shared path that weaves through the corridor creating the primary route along the park lengths.
3. Secondary Shared Path - this is a 2.2m wide shared path that creates an alternative route and loops through the parkland key spaces.
4. Informal paths - these are playful trails created using a variety of surfaces or stepping stones that links between paths and key locations.

The circulation strategy has been developed based on the following principles:

- Equitable access and movement paths are prioritised throughout the corridor, particularly around the station plaza's and between adjacent car parks and bus hubs.
- All primary paths from car parks and bus hubs are sheltered by the viaduct (where possible).
- Fast cyclists and pedestrian conflicts are mitigated through separate path networks.
- Park and station plaza paths link to the surrounding street path networks and desire lines.
- A path crosses the corridor to link adjacent perpendicular streets.
- All shrub and understorey planting within 3m of paths are low to avoid sight-line issues and promote passive surveillance.
- Wayfinding and identity is informed through materiality and path hierarchy.
- Planting areas within forecourts directing pedestrians to station entrances.
- Paths are designed to enhance user experience including PSP - refer materiality sections.
- All paths have flush interfaces between surfaces allowing for universal access and overland drainage.
- Both bike shelters and undercover external bike hoops are provided in proximity to the station entrances.
- Rest points are provided along all recreational paths.
- Shade and amenity from trees and the viaduct will reduce heat load and improve comfort.

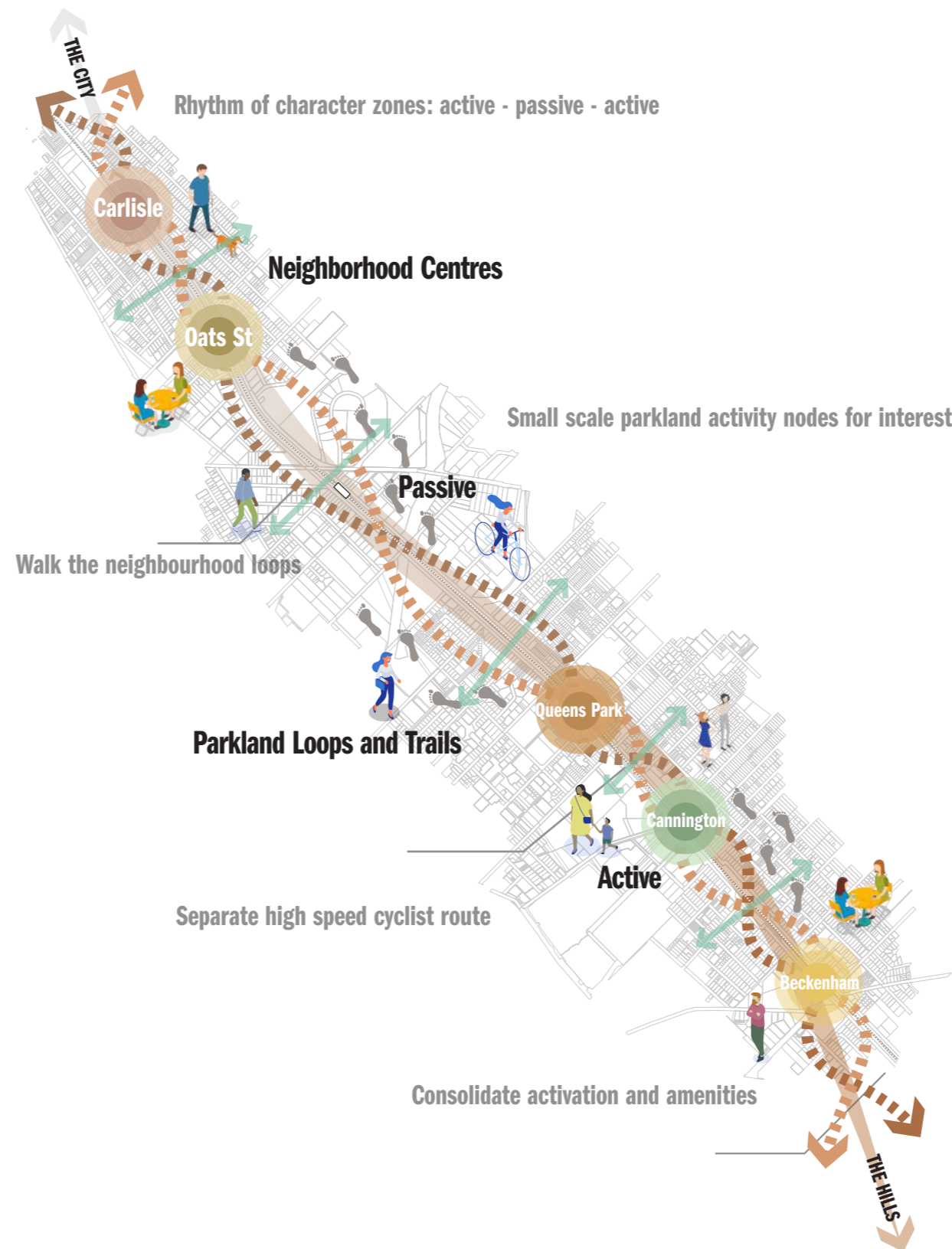

RECREATIONAL WALKING



RECREATIONAL CYCLING



COMMUTER CYCLING



UNIVERSALLY ACCESSIBLE



JOGGING / RUNNING



ALL WHEELS NOT JUST BIKES

10.2 PSP CROSSING STRATEGY

PSP Strategy

The primary shared path (PSP) which runs the length of the project corridor will be separate to the recreational shared path (RSP) network.

The PSP will be retained in place where possible and new stretches will be aligned along the edge of the project corridor.

This will allow faster cyclists (particularly commuters) a safe, direct path along the edge of the transport corridor. Slower recreational cyclists and pedestrians will be focused on the path network within the corridor centre.

This separation of the PSP and RSP networks will attempt to reinforce a strategy of faster speeds to transport corridors and slower speeds to recreational corridors.

This strategy will reduce pedestrian and cyclist conflict and improve safety via the following principles:

- Separate PSP and RSP network where possible.
- Control and consolidate conflict locations (crossing points).
- Clearly defined and delineated PSP and Pedestrian areas through pavement materiality, colour and signage.
- Introduce good sight-lines and refuge for pedestrians to crossing points.
- Provide refuge locations for pedestrians at bus stop locations.
- Control shared plaza spaces with negotiated and directed PSP traffic.
- Consider the requirements and controls of E-Scooters throughout the park via signage and additional pavement markings.

SPEED REDUCTION



SAFETY MARKING



PHYSICAL SEPARATION



CONTROL CROSSING POINTS THROUGH PLANTING



PROVIDE PEDESTRIAN REFUGE



HIGHLIGHT CONFLICT ZONES



SLOW CYCLIST AT CROSSINGS



CROSS CORRIDOR CONNECTOR PATHS (TYPICAL)

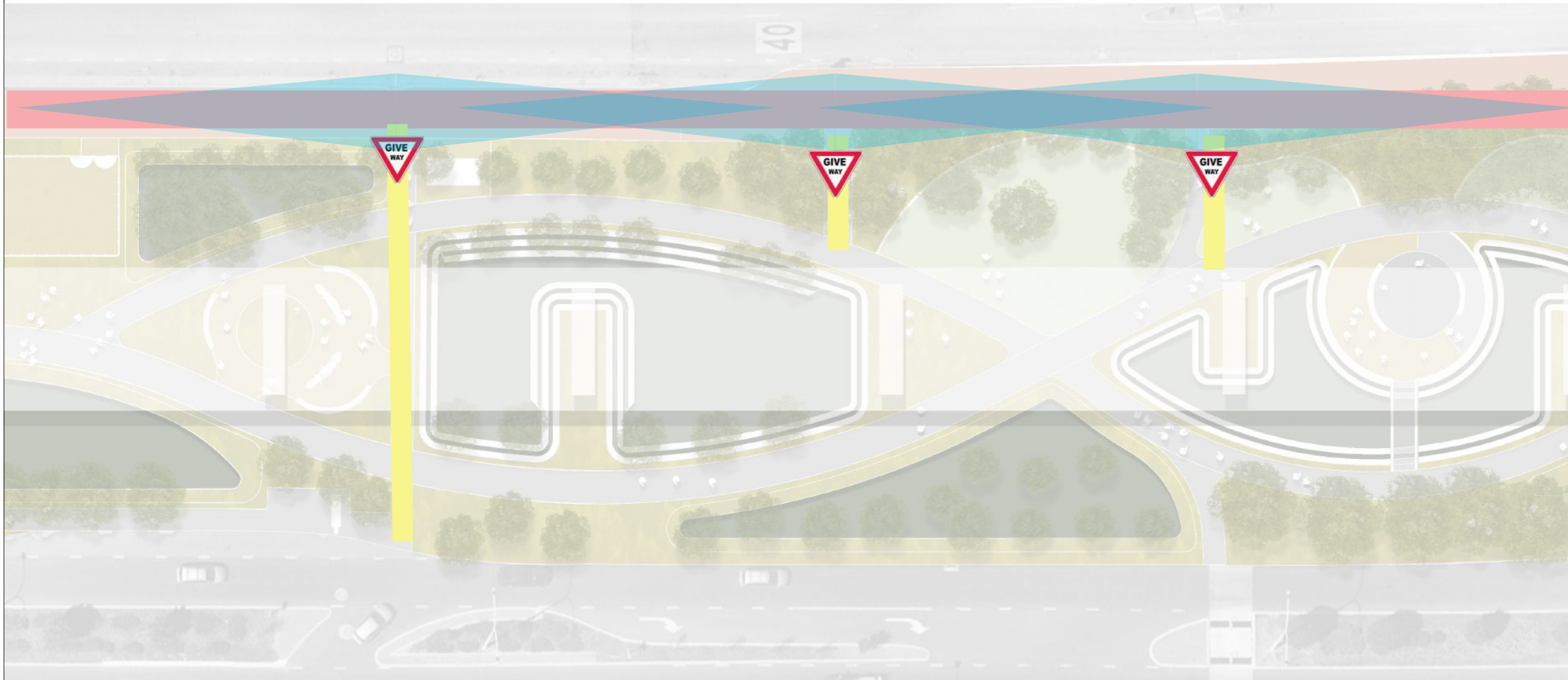

Asphalt PSP



 Pedestrian give way line marking



Sight line cones as per Main Roads guide

HAMILTON STREET CROSSING

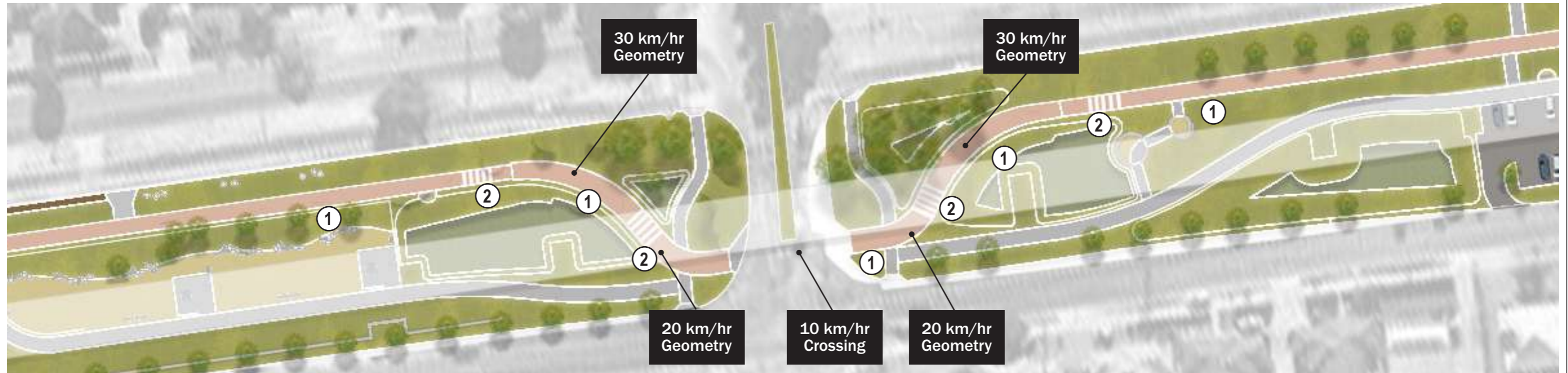

- ① Asphalt PSP
(Signage and Marking as required)
- ② Transverse Warning Markings

QUEENS PARK STATION

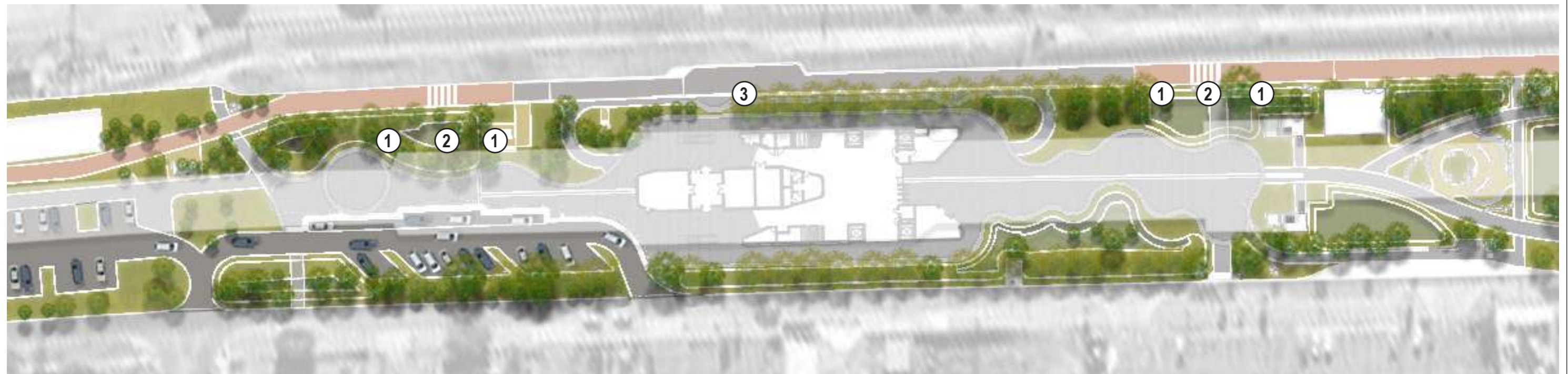

- ① Asphalt PSP
(Signage and marking as required)
- ② Transverse Warning Markings
- ③ PSP with Feature Finish
(Applied paint or other)

WHARF STREET CROSSING

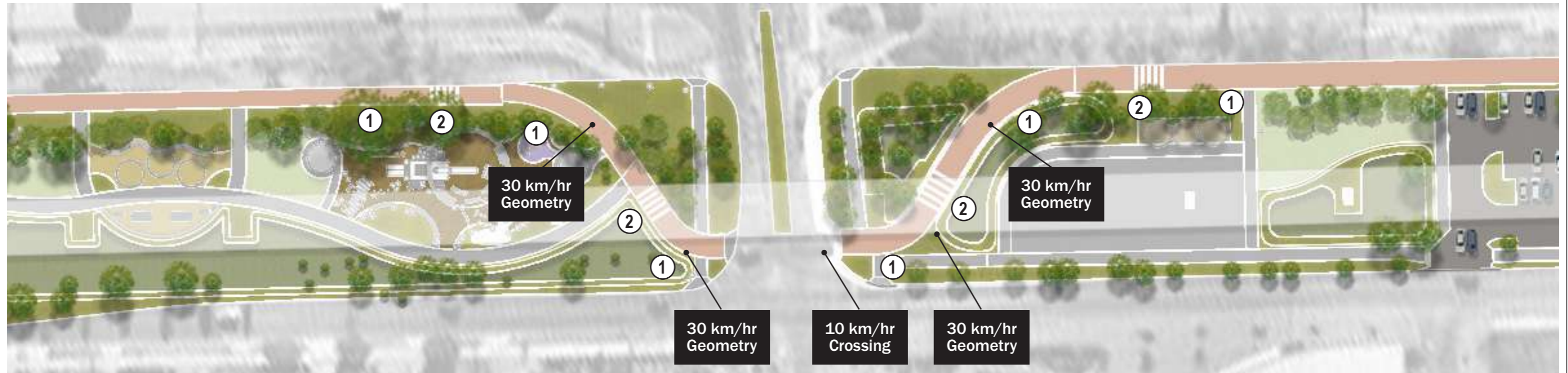

- ① Asphalt PSP
(Signage and Marking as required)
- ② Transverse Warning Markings

CANNINGTON STATION

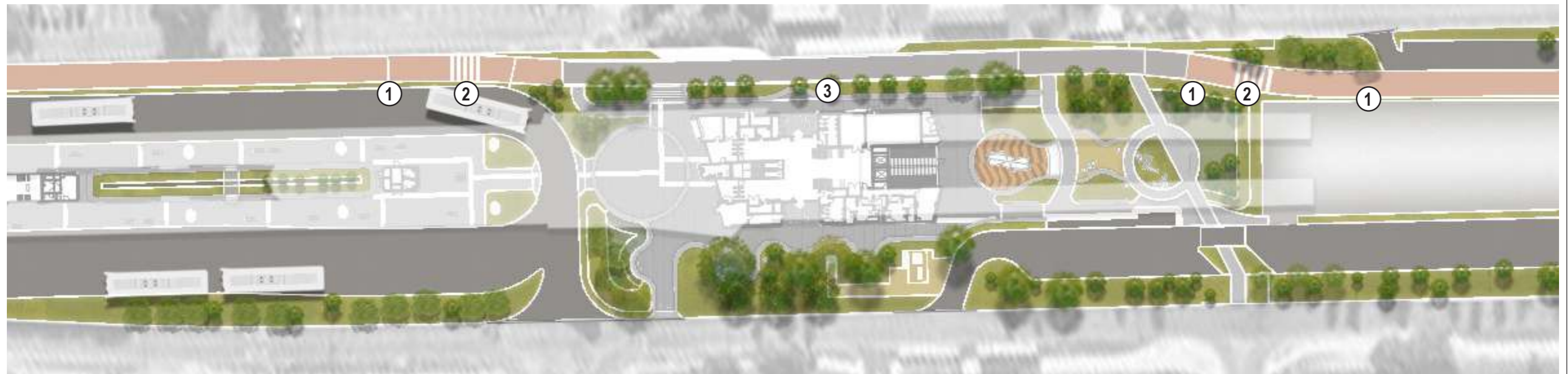

- ① Asphalt PSP
(Signage and marking as required)
- ② Transverse Warning Markings
- ③ PSP with Feature Finish
(Applied paint or other)

10.3 SPECIFIC ACCESS PLANS

QUEENS PARK STATION

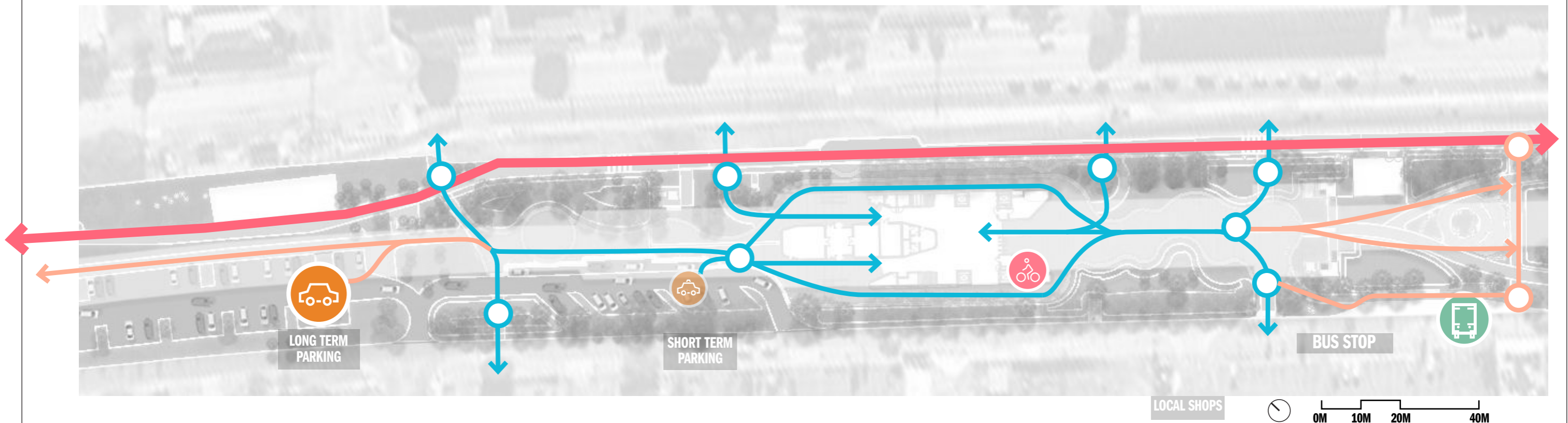

- ↔ PSP
- ↔ Pedestrian Path
- ↔ Plaza Connectors
- 🚲 Bike Store
- 🚗 Short-term Car Parking
- 🚗 Long-term Car Parking
- 🚌 Bus Stop
- Pedestrian Path Entry Points
- Plaza Entry Points

CANNINGTON STATION

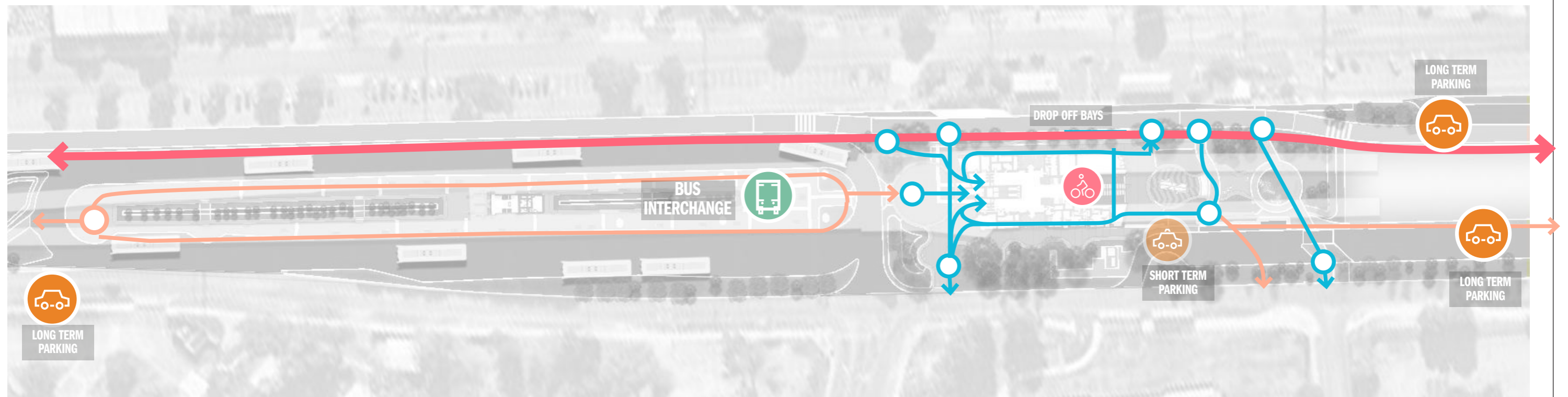

- ↔ PSP
- ↔ Pedestrian Path
- ↔ Plaza Connectors
- Pedestrian Path Entry Points
- Plaza Entry Points
- 🚲 Bike Store
- 🚗 Short-term Car Parking
- 🚗 Long-term Car Parking
- 🚌 Bus Interchange

10.4 SECURITY & CPTED STRATEGY

CPTED

Crime Prevention Through Environmental Design (CPTED) is central to all design decisions. Primarily people need to feel safe to support the use of the stations and public realm.

The project aspires towards design excellence - celebrating local culture, encouraging pride and a sense of community.

Activation is encouraged through provision of numerous amenities in addition to the train stations - playgrounds, youth plazas, event spaces, recreation equipment etc.

Wayfinding is intuitive as well as signed, with paths, entries, + exits all visually obvious for all site users.

A full suite of PTA and wayfinding signage is under development to provide clear direction around site.

Multiple pathways are provided through out the corridor to provide options to change route or direction easily if needed.

An effective lighting design provides a safe, visible environment after dark. Refer to lighting strategy (10.5) for more detail.

Low plant species mixes, clear tree trunks and carefully placed infrastructure (transformers, pumps etc) all clear site lines throughout the corridor.

Fencing is avoided although when necessary, are low and visually permeable.

Access is restricted to the at-grade section of corridor through cyclone fencing or noise walls screened by tall planting where possible. Any tall species will be avoided within 3m of pedestrian or cycle paths.

Maintenance of the parkland and plazas is to create a 'cared for' image. Graffiti or vandalism is to be attended to quickly. Materials are chosen to minimize opportunity for vandalism and enable easy removal.

Station Plazas

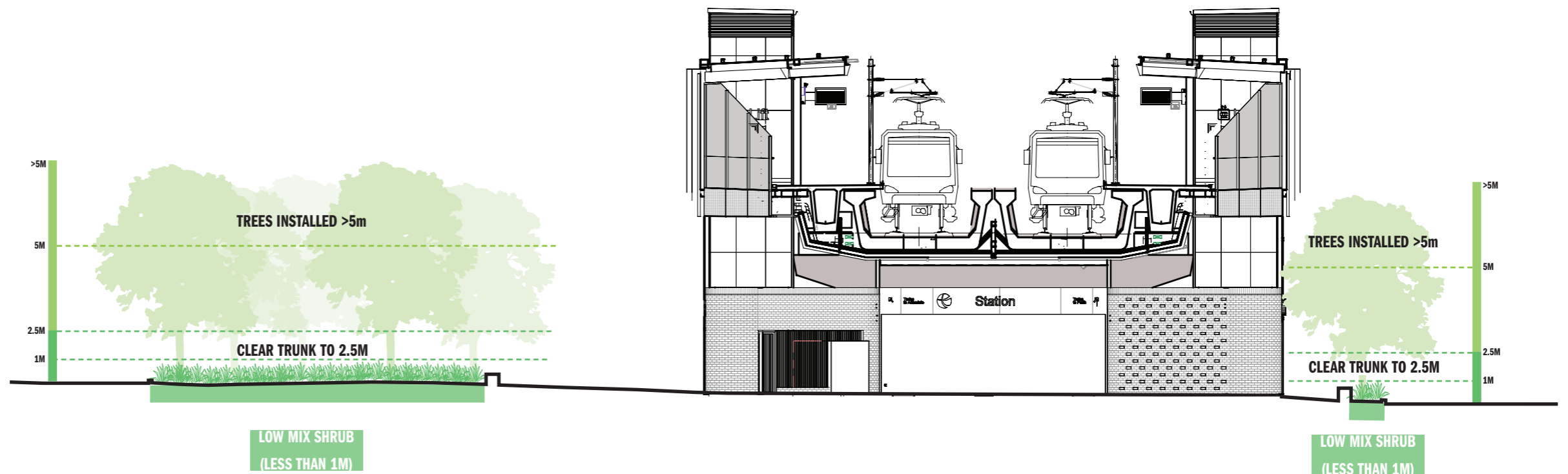

Parkland / Viaduct

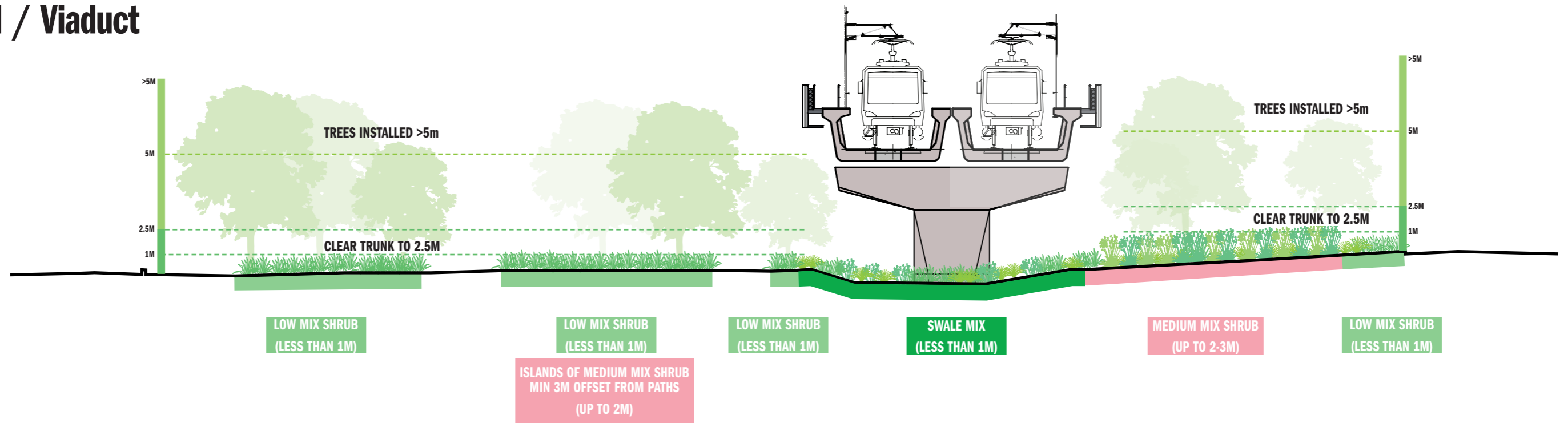

Rail at-grade / re-veg areas

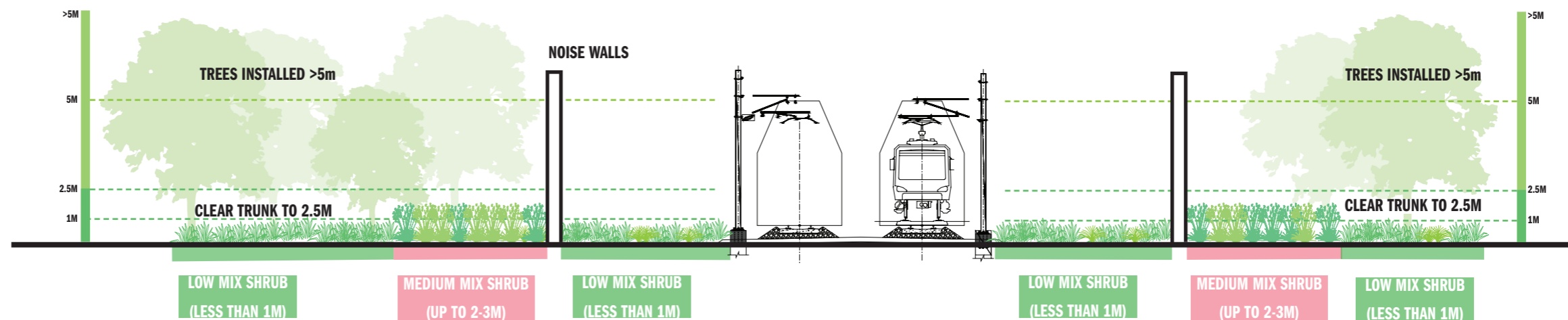

10.5 LIGHTING STRATEGY

Lighting plays an important role in enhancing the sense of safety. Good lighting design can assist in reducing antisocial behaviour, improved visibility and therefore more frequent use of the Linear Park by the community.

Lighting objectives include:

- Enhance perception of a safe, welcoming environment
- Be integrated into and accentuate the design
- Destination experience for pedestrians

- Activating the space both day and night at station precincts
- Increase visibility at night
- Assisting wayfinding
- Enrich the user experience
- Meet the required specifications

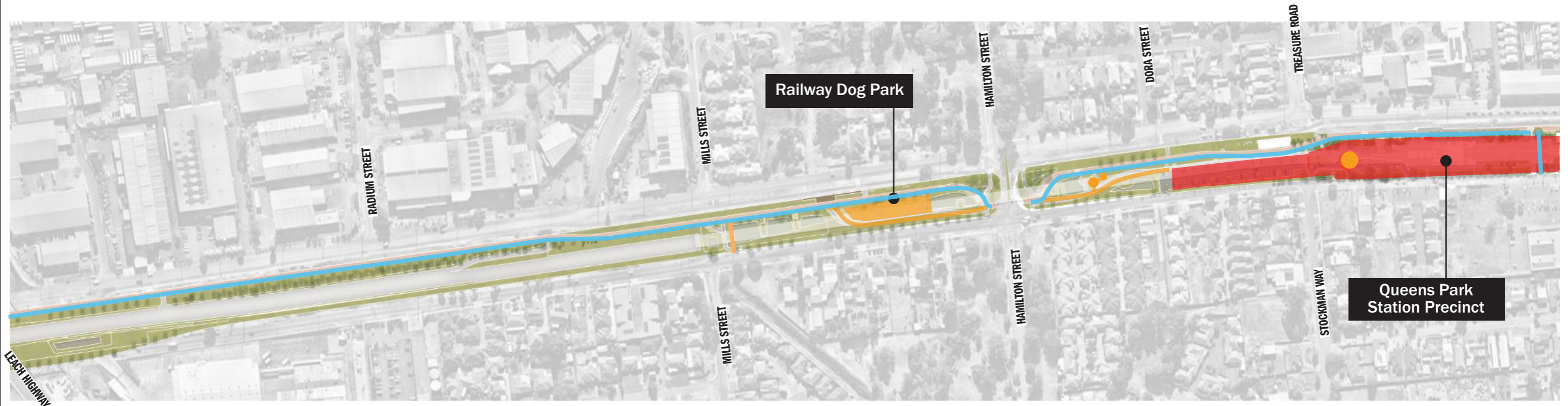

Legend

- Station**
 - Mode 1 - Dark to Last Trains / Buses
 - Mode 2 - Last Trains to Light
- Parklands**
 - Dark - 9PM (or per LGA regulations)
- Urban Connectors**
 - All night

Subject to ongoing design development and change via coordination and approval by stakeholders: Security working group, PTA, LGAs



